

Accessories for CST



Order specifications:

Bracket for surface mounting with cable gland	960 009 08
Bracket for surface mounting with concealed cable entry	960 009 07
Base with integrated tube, \varnothing 25 mm, 110 mm long, plastic, incl. rubber seal	975 849 11
Tube with cable gland, \varnothing 25 mm	
100 mm long	960 009 10
250 mm long	960 009 25
400 mm long	960 009 40
800 mm long	960 009 80
Bracket for tube mounting	960 009 09
Tube \varnothing 25 mm, all anodized aluminium	
100 mm long	975 849 10
250 mm long	975 849 25
400 mm long	975 849 40
800 mm long	975 849 80
Base for tube mounting \varnothing 25 mm, plastic, incl. rubber seal	975 849 90
Base for tube mounting \varnothing 25 mm, metal, incl. rubber seal	975 849 91
Contact box for cable exit at side, with mounting material	975 849 01
Contact box with magnetic base and cable exit at side	975 849 04
Bracket for tube mounting with cable gland	960 009 01

Technical Diagrams:

See attached page

Compact Signal Tower CST 60



Catalogue New Products

Brief Introduction

WERMA Signaltechnik is an international company headquartered in southern Germany between Stuttgart and the Swiss border.

Thanks to concentrated specialization and more than 50 years of experience in the field of signaling,



WERMA occupies the position of technology leader and trend-setter in this sector.

WERMA offers a wide range of signal towers, optical, audible, optical-audible and Ex Signal devices that can be found in various industrial applications all over the world.

The Compact Signal Tower CST 60 is an optical-audible signal device that was especially designed to meet the requirements of price sensitive markets. It combines a competitive price with cutting edge LED technology and high quality appearance.

The CST 60 is available in LED permanent or LED blinking light versions. The high protection rating IP 54 makes the Signal Tower suitable for nearly every indoor and outdoor application. A version with an elec-



tronic buzzer for audible signalization is also available. The innovative LED technology ensures a long life-duration of up to 50,000 hours and good visibility together with very low current consumption. Thanks to a large variety of accessories the Compact Signal Tower CST 60 can be used in a wide range of industrial applications.



CST 60 - Compact Signal Tower



- Pre-assembled Signal tower system 60 mm Ø
- LED permanent, LED blinking and buzzer versions available
- LED versions using integrated LEDs with long life-duration, maintenance-free
- Terminal-block with screw-less clamp mechanism for user-friendly wiring
- Only one mounting base for surface and tube mounting

Technical specifications:

Dimensions (Diameter x Height):	2 tier: 60 x 132 mm 3 tier: 60 x 165 mm
Housing:	Housing parts: PC Mounting base: PA fibreglass, high-impact
Fixing:	Base / Bracket mounting Tube mounting, for tube Ø 25 mm
Connection:	Screw-free clamp connection max. 1,5 mm ²
Cable entry:	Cable diameter max. 11 mm
Protection rating:	IP 54 for versions without buzzer IP 40 for buzzer versions
Life-duration:	Up to 50.000 hrs

Order specifications:

		Order no.	Voltage	Current Consumption
LED-Permanent Light	red / green	696.019.75	24 V AC/DC	< 30 mA per tier
	red / yellow	696.029.75	24 V AC/DC	< 30 mA per tier
	red / yellow / green	696.009.75	24 V AC/DC	< 30 mA per tier
LED-Blinking Light (tier 2 and 3 blinking)	red / green	696.119.75	24 V AC/DC	< 40 mA per tier
	red / yellow	696.129.75	24 V AC/DC	< 40 mA per tier
	red / yellow / green	696.109.75	24 V AC/DC	< 40 mA per tier

		Order no.	Voltage	Current Consumption
LED-Permanent Light with buzzer	red / green	696.049.75	24 V DC	< 30 mA per tier buzzer < 25 mA
	red / yellow	696.059.75	24 V DC	< 30 mA per tier buzzer < 25 mA
	red / yellow / green	696.039.75	24 V DC	< 30 mA per tier buzzer < 25 mA
LED-Blinking Light with buzzer (tier 2 and 3 blinking)	red / green	696.149.75	24 V DC	< 40 mA per tier buzzer < 25 mA
	red / yellow	696.159.75	24 V DC	< 40 mA per tier buzzer < 25 mA
	red / yellow / green	696.139.75	24 V DC	< 40 mA per tier buzzer < 25 mA

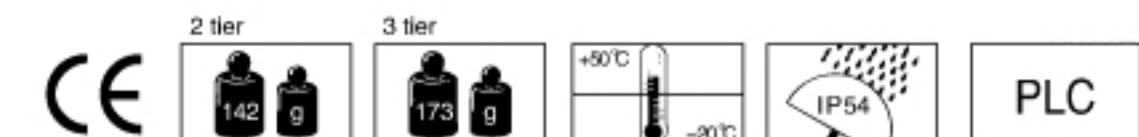

CST 60

Technical Diagrams

CST 60 Accessories

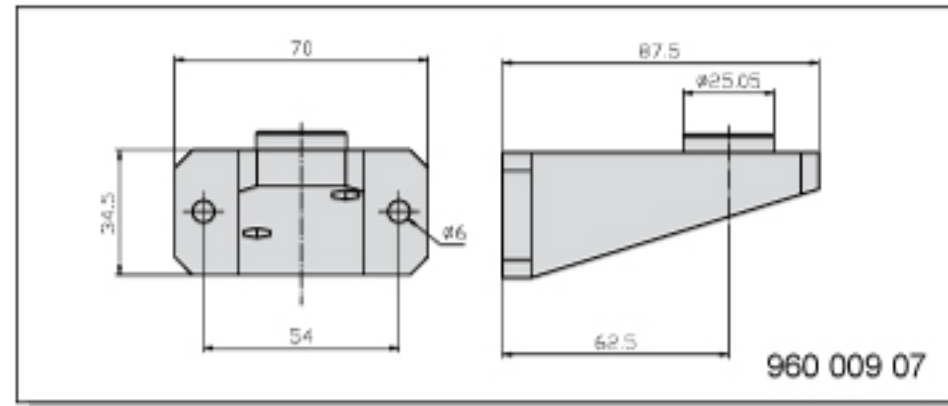

960 009 07

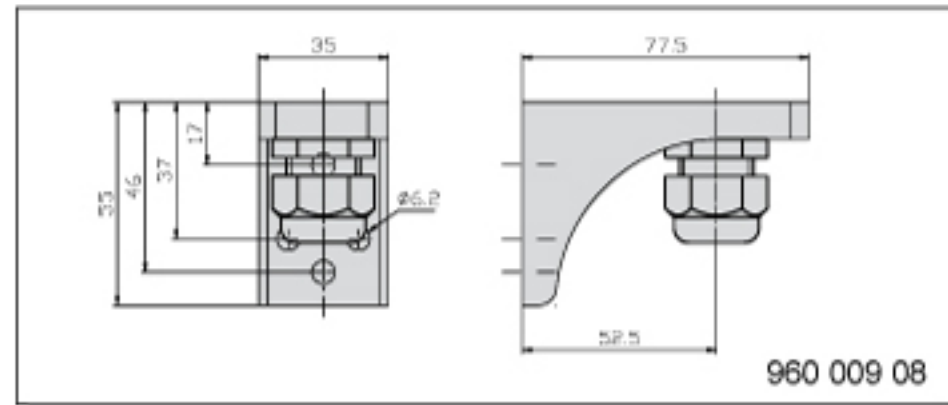

960 009 08

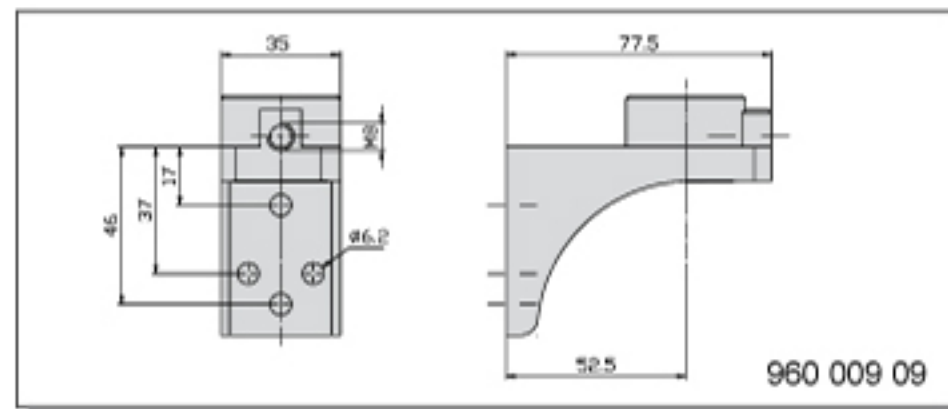

960 009 09

CST 60

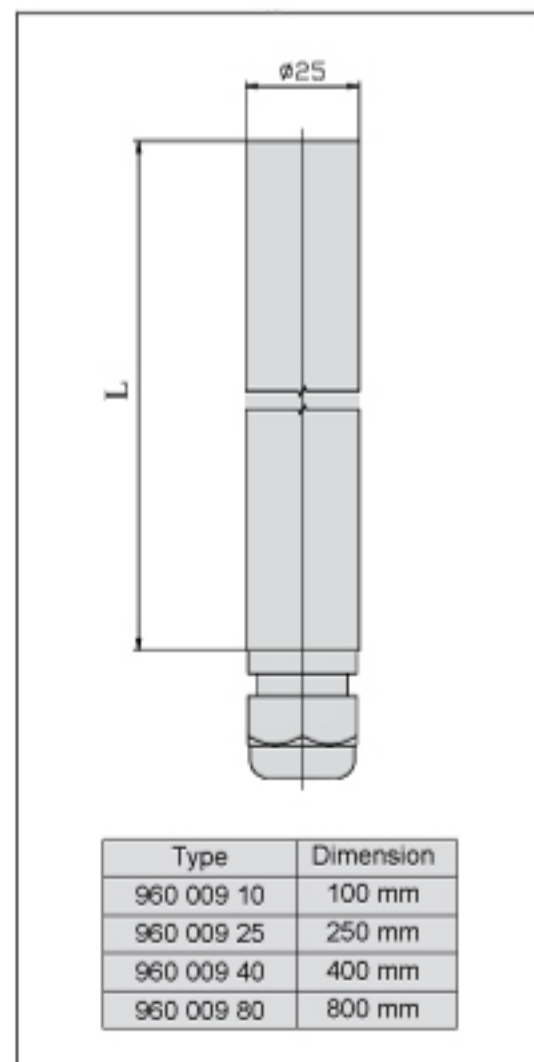
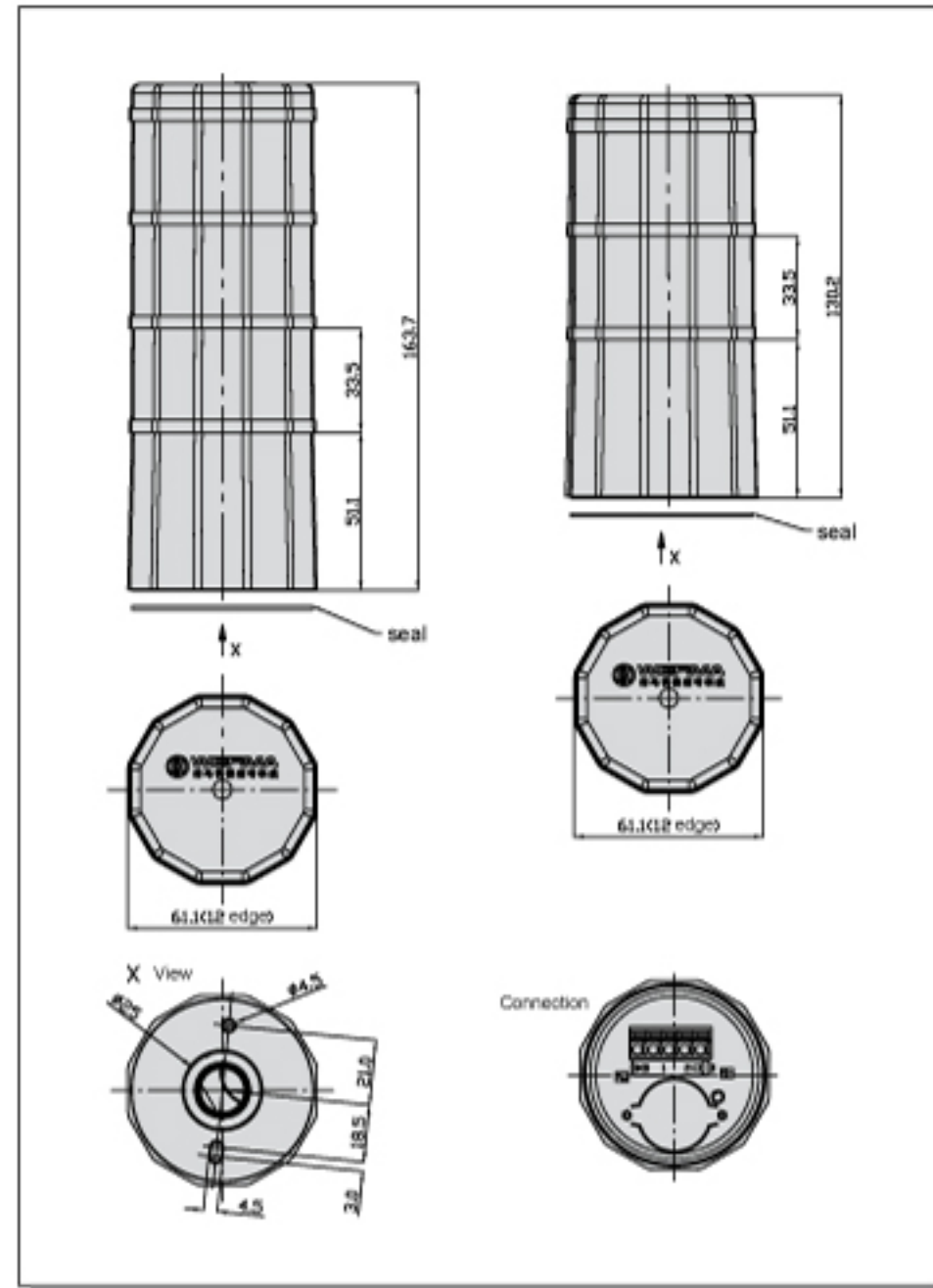

Type	Dimension
960 009 10	100 mm
960 009 25	250 mm
960 009 40	400 mm
960 009 80	800 mm

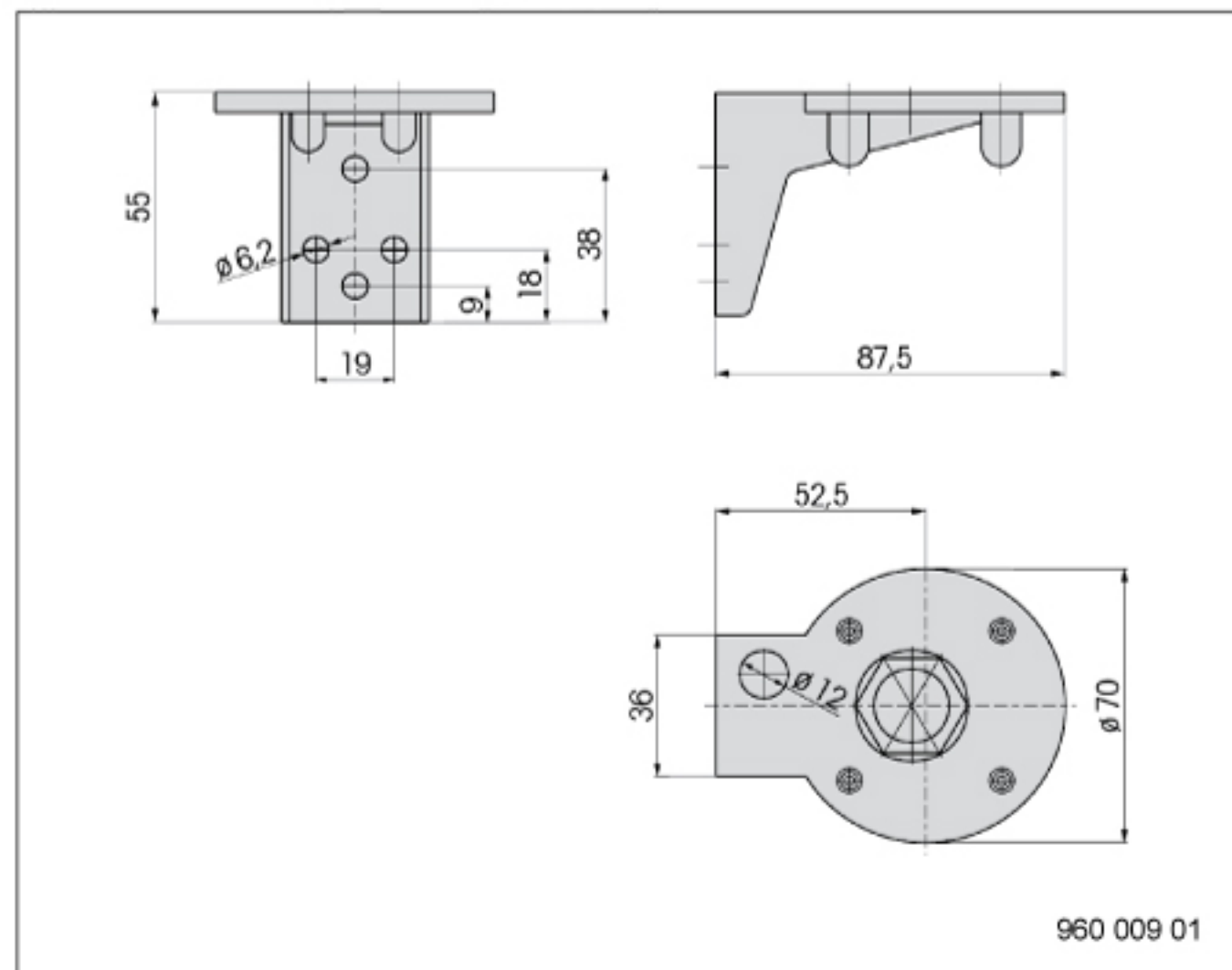

960 009 01

CST 60

Technical Diagrams

CST 60 Accessories

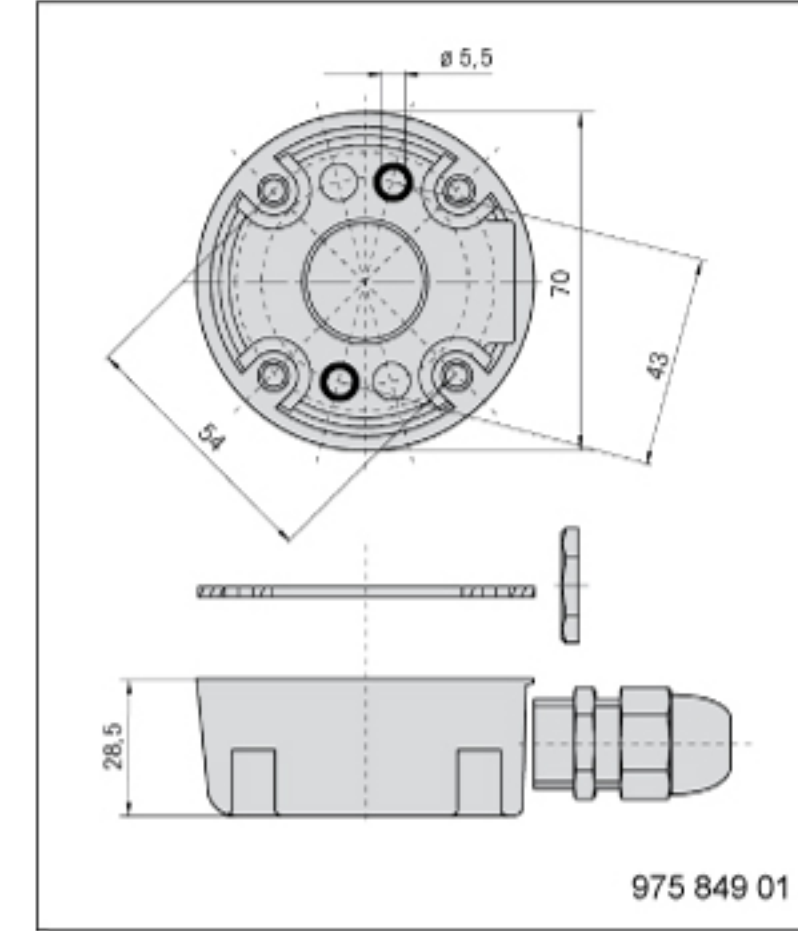

975 849 01

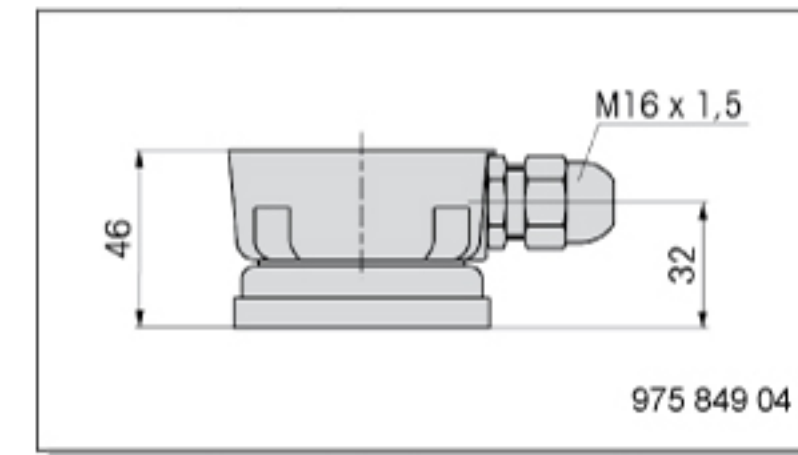

975 849 04

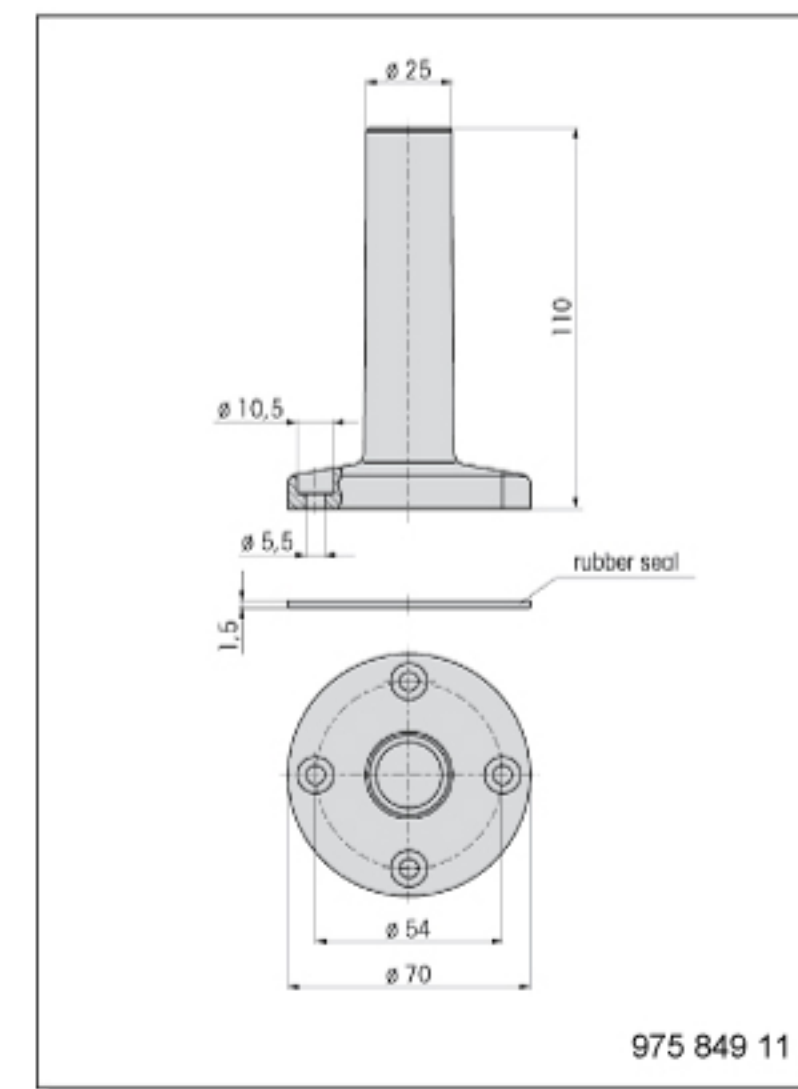

975 849 11

CST 60 Accessories

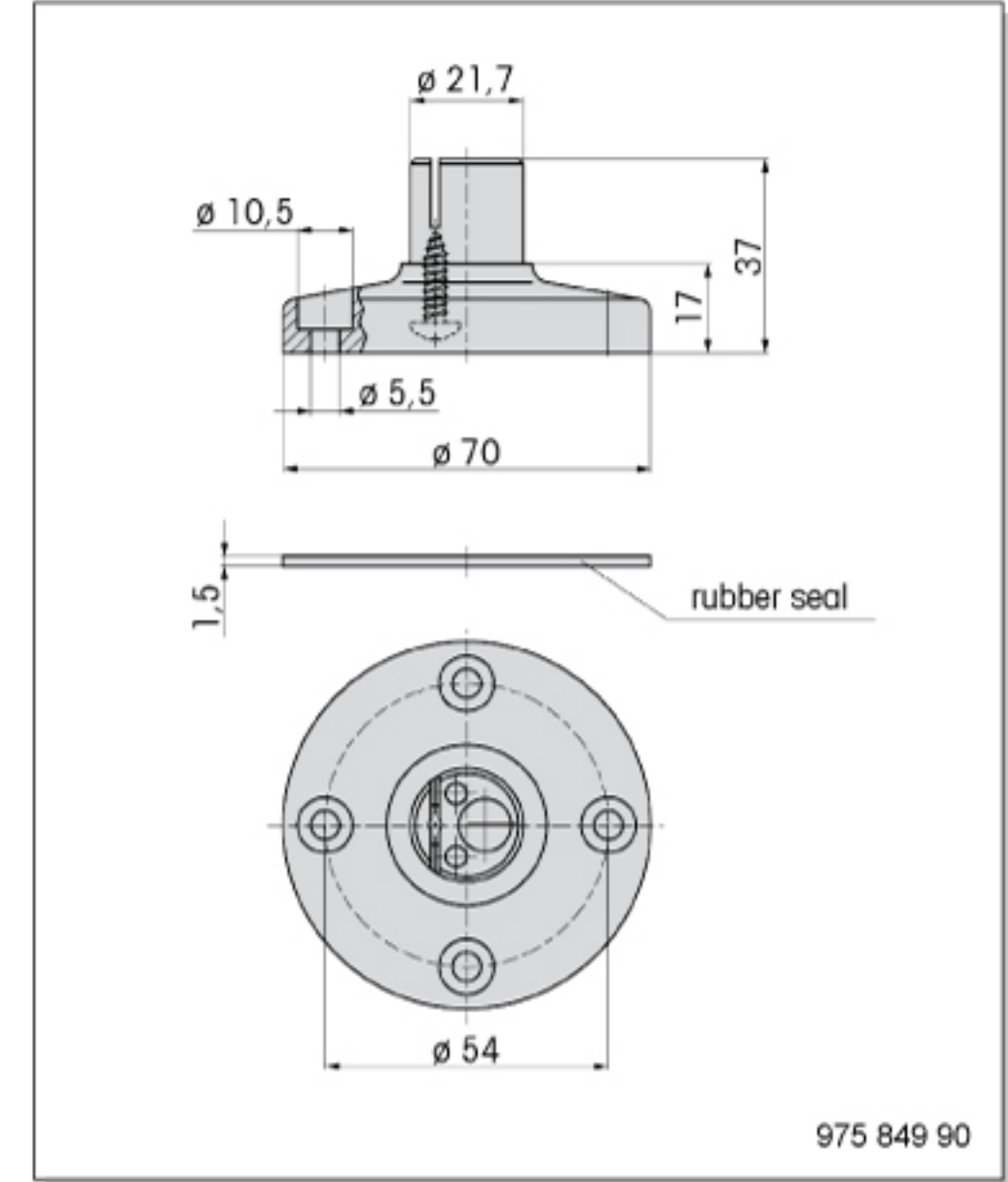

975 849 90

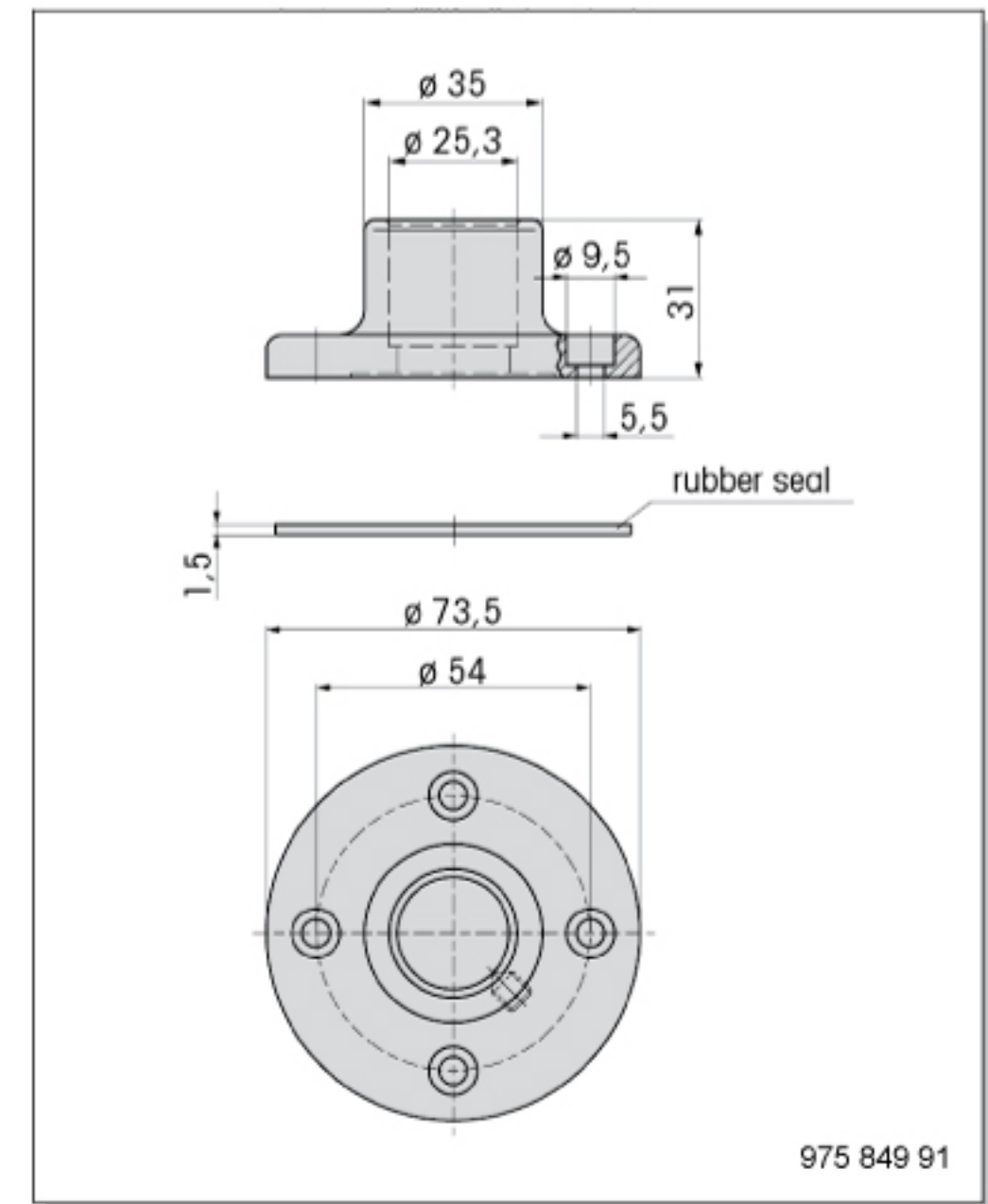

975 849 91