

METRON



METRON

MAIN FEATURES

Light curtains for industrial and civil applications where it is necessary to detect, measure, and recognise objects.

Depending on the number and position of the beams engaged by an object, **METRON** can provide real time information to a PLC or PC useful to:

- **Detect the presence or absence of objects**
- **Perform a count**
- **Detect a position**
- **Detect a shape or a profile**
- **Measure dimensions**

Models A equipped with 4 programmable solid state outputs.

Models B equipped with 2 programmable solid state outputs and an RS 485 serial interface.

Models C equipped with two antivalent solid state outputs for "status of controlled area".

Metronconf Configuration software for PC, with practical **graphic interface**, supplied with each light curtain (models A and B only).

Beam spacing available from 5 mm to 75 mm.

Protected height from 140 mm to 2525 mm.

Max. range 16 m (10 mm and 30 mm models).

Connections with M12 and M16 connectors. Up to 50 m of electrical connections without shielded cables.

Possibility of connection of up to 8 Metron B light curtains as nodes of an RS 485 serial line for simultaneous detection of multiple dimensions and complex measurements.

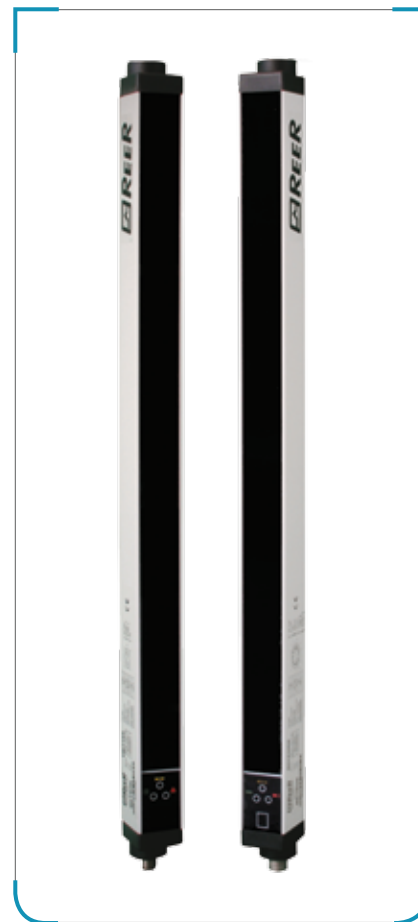

THE METRON RANGE

METRON A

4 solid state outputs 0/24V with programmable functions

Solution providing simple on/off information related to the occurrence of the programmed conditions

Ideal for object recognition, quality control, detection of dimensional limits

METRON B

RS-485 serial line + two solid state outputs 0/24V with programmable functions

Solution providing complete and detailed information on the status of each beam via the RS 485 serial line and, by means of the two solid state outputs, further on/off information related to the occurrence of the programmed conditions

Ideal for dimensional measurement, detection of object profile and position

METRON C

Two solid state antivalent outputs 0/24V without the need for programming

Solution providing simple on/off information related to the status of the controlled area

Ideal for piece counting and detection of object presence/absence in the controlled field

APPLICATION EXAMPLES



Measurement of the height of objects in transit on conveyor systems

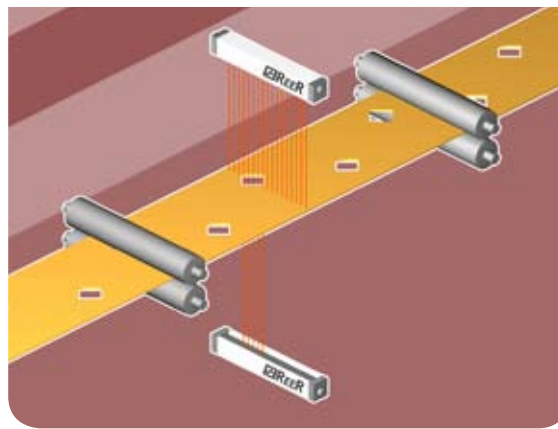

Quality control: verification of presence / absence / position of holes

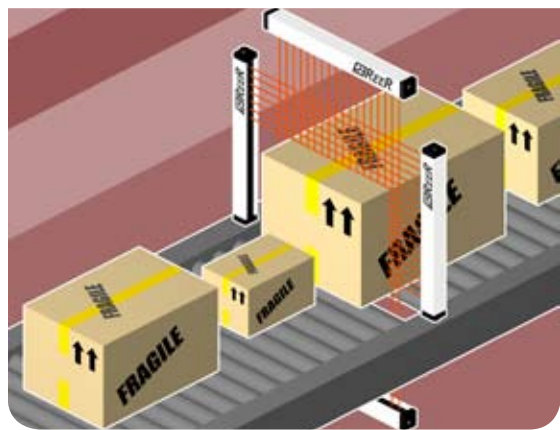

Two-dimensional detection of objects in transit on conveyor systems with use of 2 light curtains. If necessary, the calculation of the volume can be made by means of a third horizontal light curtain, or considering the transit speed

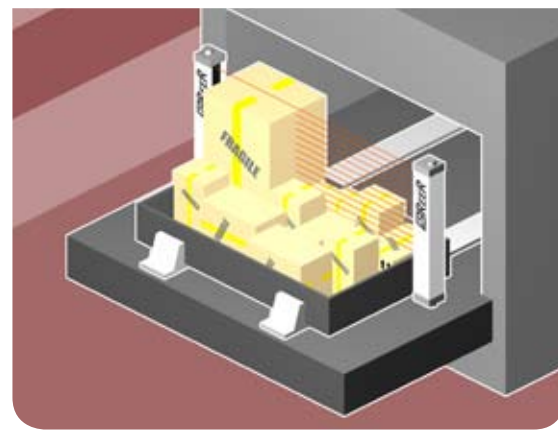

Automatic warehouses: detection of maximum height of the objects present in the boxes for efficient management of the machine's capacity

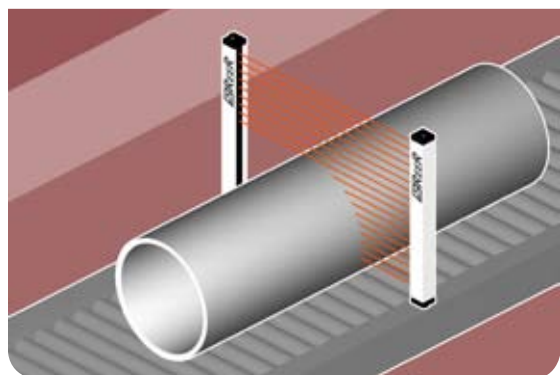

Measurement and identification of cylinders of various sizes



Detection of position and profile of pieces in automatic painting systems

METRON

APPLICATION EXAMPLES

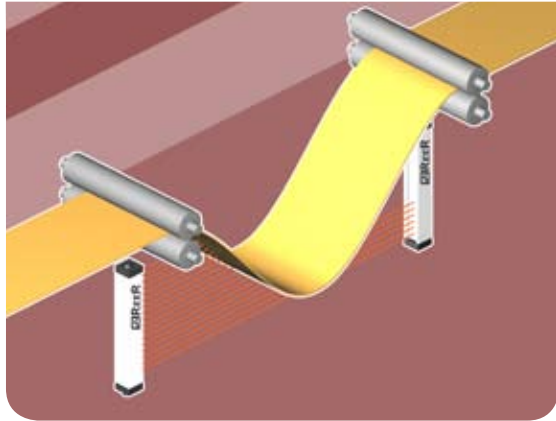

Loop control

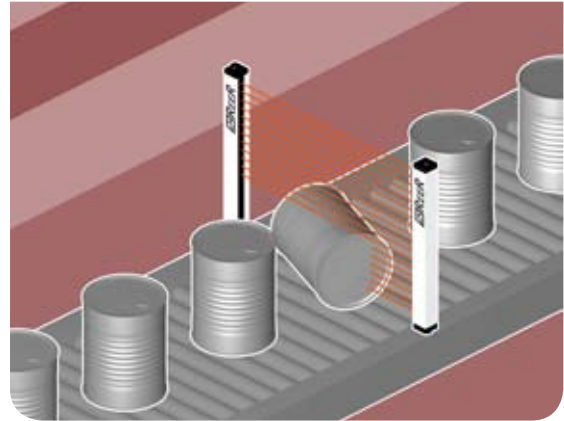

Quality control: verification of correct positioning of objects

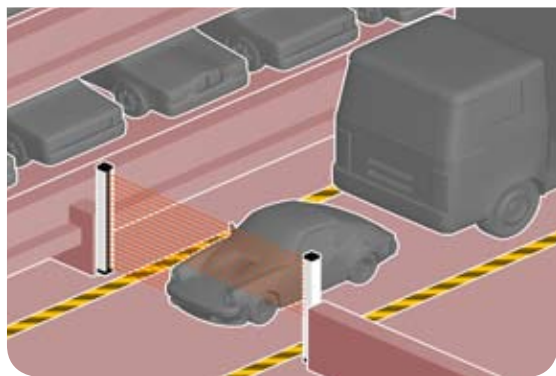

Detection of overall dimensional limits of vehicles for vehicle handling in automatic parking garages

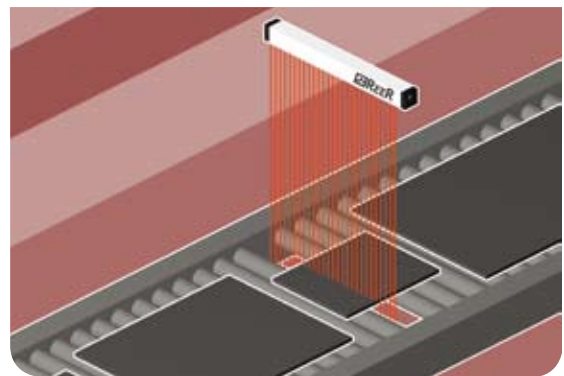

Measurement of the width and position of panels or sheets of material in transit on roller units or conveyor belts

Special customised models available on request.

Special models in conformity with the "ATEX Directive" 94/9/CEE – Dust Zone 22 - Gas Zone 2 available on request.

TECHNICAL FEATURES		
Controlled heights mm	140 ÷ 2525	
Beam spacing mm	5 - 10 - 25 - 30 - 50 - 75	
Max range m	2 – for models with beam spacing 5 mm 6 - for models with beam spacing 25 - 50 - 75 mm 16 - for models with beam spacing 10 - 30 mm	
Measurement time	(2.25 ms + 70 µs x n beams) x 2	
Outputs	Metron A	4 - solid state 0 / 24V programmable - PNP 100 mA at 24Vdc
	Metron B	RS-485 Serial line (up to 8 nodes) 2 - solid state 0 / 24V programmable - PNP 100 mA at 24Vdc
	Metron C	2 - solid state 0 / 24V antivalent - PNP 100 mA at 24Vdc
Inputs (on receiver) (Metron A and B only)	1 - digital with programmable functions - 0/24V	
Metron A and B programming	via Metronconf configuration software	
Metron A and B programming interface	RS-232 serial line	
Synchronisation between emitter and receiver	Optical or via cable, selectable	
Electrical connections	Metron A and B	1 connector M12 8-pole (emitter) 1 main connector M16 12-pole (receiver) 1 secondary connector M8 3-pole for RS-232 line for programming (receiver)
	Metron C	Metron C 2 M12 5-pole connectors (emitter and receiver)
Signalling	7-segment display and LEDs for operating status and light curtain self-diagnosis	
Power supply Vdc	24 ± 20%	
Max. length connection cables between light curtain and interface m	50	
Operating temperature °C	0 ÷ 55	
Protection rating	IP 65	
Fastening mode	3: back slot, side slot, or to the top and lower end	
Cross-section dimensions mm	35 x 45	

CHARACTERISTICS OF METRONCONF CONFIGURATION SOFTWARE	
Possibility for on-line display on PC screen during operation (via RS 232)	Status of each individual beam and solid state outputs
Configurable parameters	Operating logic (conditions for output activation), parameters of the RS-485 serial line (transmission method, baud rate, parity, start-stop characters, binary, hex, ascii format, etc.)

METRON

MODELS

Beam spacing 5 mm	ME 150	ME 300	ME 450	ME 600	ME 750	ME 900	ME 1050	ME 1200	-	-	-	-	-	-	-	-
Controlled heights mm	145	295	445	595	745	895	1045	1195	-	-	-	-	-	-	-	-
Number of beams	30	60	90	120	150	180	210	240	-	-	-	-	-	-	-	-
Overall height mm	261	411	561	711	861	1011	1161	1311	-	-	-	-	-	-	-	-

Beam spacing 10 mm	ME 151	ME 301	ME 451	ME 601	ME 751	ME 901	ME 1051	ME 1201	ME 1351	ME 1501	ME 1651	ME 1801	ME 1951	ME 2101	ME 2251	ME 2401	-
Controlled heights mm	140	290	440	590	740	890	1040	1190	1340	1490	1640	1790	1940	2090	2240	2390	-
Number of beams	15	30	45	60	75	90	105	120	135	150	165	180	195	210	225	240	-
Overall height mm	261	411	561	711	861	1011	1161	1311	1461	1611	1761	1911	2061	2211	2361	2511	-

Beam spacing 25 mm	-	ME 302	ME 452	ME 602	ME 752	ME 902	ME 1052	ME 1202	ME 1352	ME 1502	ME 1652	ME 1802	ME 1952	ME 2102	ME 2252	ME 2402	ME 2552
Controlled heights mm	-	275	425	575	725	875	1025	1175	1325	1475	1625	1775	1925	2075	2225	2375	2525
Number of beams	-	12	18	24	30	36	42	48	54	60	66	72	78	84	90	96	102
Overall height mm	-	411	561	711	861	1011	1161	1311	1461	1611	1761	1911	2061	2211	2361	2511	2661

Beam spacing 30 mm	-	ME 303	ME 453	ME 603	ME 753	ME 903	ME 1053	ME 1203	ME 1353	ME 1503	ME 1653	ME 1803	ME 1953	ME 2103	ME 2253	ME 2403	ME 2553
Controlled heights mm	-	270	420	570	720	870	1020	1170	1320	1470	1620	1770	1920	2070	2220	2370	2520
Number of beams	-	10	15	20	25	30	35	40	45	50	55	60	65	70	75	80	85
Overall height mm	-	411	561	711	861	1011	1161	1311	1461	1611	1761	1911	2061	2211	2361	2511	2661

Beam spacing 50 mm	-	-	ME 455	ME 605	ME 755	ME 905	ME 1055	ME 1205	ME 1355	ME 1505	ME 1655	ME 1805	ME 1955	ME 2105	ME 2255	ME 2405	ME 2555
Controlled heights mm	-	-	400	550	700	850	1000	1150	1300	1450	1600	1750	1900	2050	2200	2350	2500
Number of beams	-	-	9	12	15	18	21	24	27	30	33	36	39	42	45	48	51
Overall height mm	-	-	561	711	861	1011	1161	1311	1461	1611	1761	1911	2061	2211	2361	2511	2661

DBeam spacing 75 mm	-	-	-	ME 607	ME 757	ME 907	ME 1057	ME 1207	ME 1357	ME 1507	ME 1657	ME 1807	ME 1957	ME 2107	ME 2257	ME 2407	ME 2557
Controlled heights mm	-	-	-	525	675	825	975	1125	1275	1425	1575	1725	1875	2025	2175	2325	2475
Number of beams	-	-	-	8	10	12	14	16	18	20	22	24	26	28	30	32	34
Overall height mm	-	-	-	711	861	1011	1161	1311	1461	1611	1761	1911	2061	2211	2361	2511	2661

DIMENSIONS mm

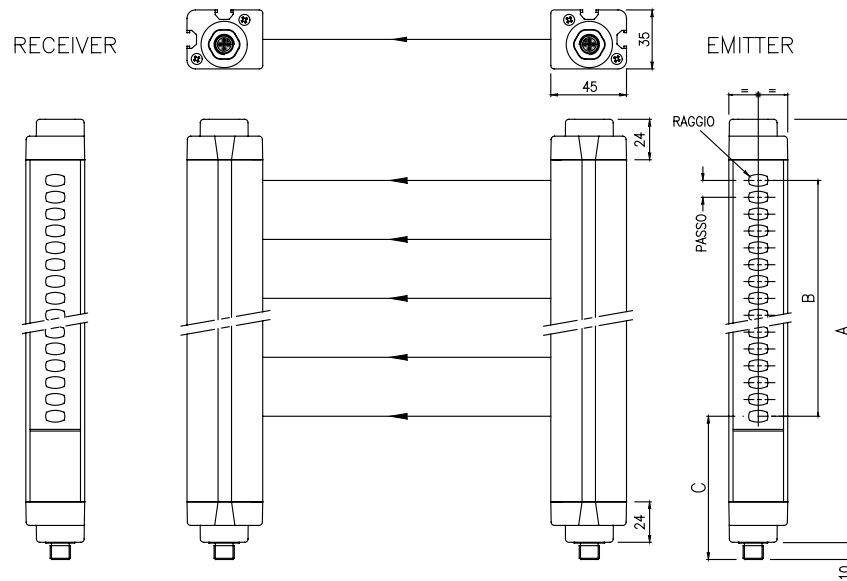

Model ME	150	300	450	600	750	900	1050	1200	
A	251	401	551	701	851	1001	1151	1301	
B (controlled height)	$B = (\text{number of beams} - 1) \times \text{beam spacing (with cable synchronisation)}$ $B = (\text{number of beams} - 2) \times \text{beam spacing (with optical synchronisation)*}$								
C (1st beam position)	85 (for 10 - 30 models) - 93 (for 25-50-75 models)								
Mounting	2 LS type brackets with 2 inserts								
Model ME	1350	1500	1650	1800	1950	2100	2250	2400	2550
A	1451	1601	1751	1901	2051	2201	2351	2501	2651
B (controlled height)	$B = (\text{number of beams} - 1) \times \text{beam spacing (with cable synchronisation)}$ $B = (\text{number of beams} - 2) \times \text{beam spacing (with optical synchronisation)*}$								
C (1st beam position)	85 (for 10 - 30 models) - 93 (for 25-50-75 models)								
Mounting	3 LS type brackets with 3 inserts								

* In the case of optical synchronism, the beam adjacent to the upper end cap cannot be used for measurement, as it constitutes the synchronism beam.

ORDERING INFORMATION (for ordering codes see page 133)

In addition to the height and beam spacing, to uniquely define a Metron light curtain the model must also be indicated A, B or C:

Models A	4 outputs with programmable functions (e.g.: ME 1801 A)
Models B	RS-485 serial line + 2 solid state outputs 0/24V with programmable functions (e.g.: ME 1801 B)
Models C	2 solid state outputs 0/24V antivalent (without the need for programming) (e.g.: ME 1801 C)

Each type of Metron light curtain includes:

- Emitter and Receiver pair
- Mounting brackets and T-nuts
- CD-ROM containing the "Metronconf" programming software and the multi-language instruction manual

METRON

ACCESSORIES

For Metron light curtains the following accessories, to be ordered separately, are available:

• LAD laser alignment device	see page 124
• FMC floor mounting columns	see page 120
• SP deflection mirrors	see page 122
• SFB swivel fixing brackets	see page 125
• SAV vibrations dampers	see page 125
• Connectors	see below:

Connectors for Metron “A” and “B” emitter

Model	Description
C8D 5	M12, straight connector, 8 poles, pre-wired cable 5 m
C8D 10	M12, straight connector, 8 poles, pre-wired cable 10 m
C8D 15	M12, straight connector, 8 poles, pre-wired cable 15 m
C8D 95	M12, 90° angle connector, 8 poles, pre-wired cable 5 m
C8D 910	M12, 90° angle connector, 8 poles, pre-wired cable 10 m
C8D 915	M12, 90° angle connector, 8 poles, pre-wired cable 15 m
C8DM 9	M12, straight connector, 8 poles with screw terminal, PG9 cable gland
C8DM 99	M12, angle connector, 8 poles with screw terminal, PG9 cable gland
C8DM 11 new	M12, straight connector, 8 poles with screw terminal, PG9/11 cable gland
C8DM 911 new	M12, angle connector, 8 poles with screw terminal, PG9/11 cable gland

Connectors for Metron “A” and “B” receiver

Model	Description
C12D 3	M16, straight connector, 12 poles, pre-wired cable 3 m
C12D 5	M16, straight connector, 12 poles, pre-wired cable 5 m
C12D 10	M16, straight connector, 12 poles, pre-wired cable 10 m
CSL 3	3 metre cable, for connecting light curtain and PC for system configuration, equipped with one M8, 3 poles connector and one DB9 connector

Connectors for Metron “C” emitter and receiver

Model	Description
CD 5	M12, straight connector, 5 poles, pre-wired cable 5 m
CD 10	M12, straight connector, 5 poles, pre-wired cable 10 m
CD 15	M12, straight connector, 5 poles, pre-wired cable 15 m
CD 20	M12, straight connector, 5 poles, pre-wired cable 20 m
CD 95	M12, 90° angle connector, 5 poles, pre-wired cable 5 m
CD 910	M12, 90° angle connector, 5 poles, pre-wired cable 10 m
CD 915	M12, 90° angle connector, 5 poles, pre-wired cable 15 m
CDM 9	M12, straight connector, 5 poles with screw terminal, PG9 cable gland
CDM 99	M12, angle connector, 5 poles with screw terminal, PG9 cable gland



**INDUSTRIAL
SAFETY SALES INC.**

P.O. Box 126 -- 4112 Sheridan Road
Kenosha, WI 53141
Fax: (262) 652-1388
E-mail: safetysensing@earthlink.net

(262) 652-8660