



WORLD OF SENSORIC WORLD OF SENSORIC

Safety-Bumper



Safety-Bumper

ESB-11, -12, -13
ESB-21, -22, -23
ESB-31, -32, -33

- Available in almost every imaginable shape
- Extremely responsive

Safety Bumper

The purpose of Safety Bumpers is the prevention of damage caused by collisions between automatic guided vehicles (AVG's) and persons or objects.

This is accomplished:

- By immediate braking of the vehicle.
- By a soft collapsible zone on the bumper itself.

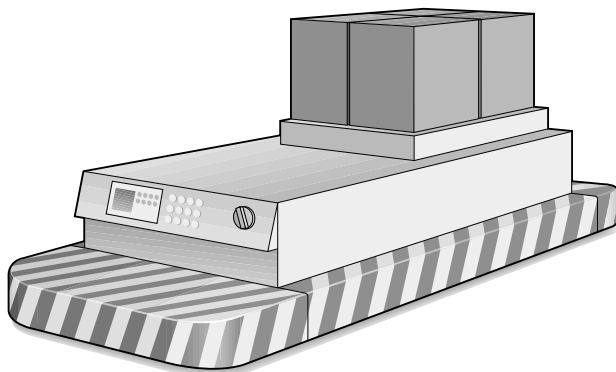

Function

The foam rubber core is deformed by a light force effect on the outer skin of the bumper.

- Two separated contact surfaces inside the switching element make contact.
- The installed defined resistance of 8.2kOhm is exceeded.
- The switching unit evaluates the contact.

The reaction pressure is adjusted ex-works and can be set according to the application.

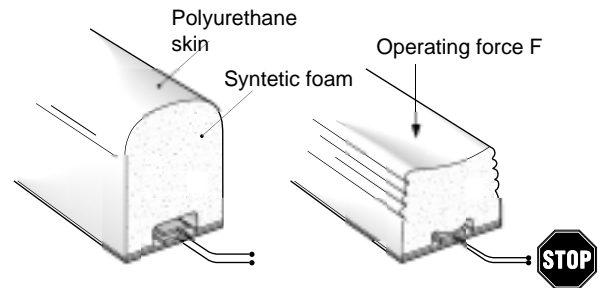

Construction

The core of the bumper consists of:

- a synthetic foam block, manufactured to shape, and covered
- Switching elements
- Aluminium frame
- Screwed base plate (3mm)

Covering

Generally Safety Bumpers are used in dry atmospheres. These are supplied with the following listed coverings and have the following characteristics.

Bumper with PUR covering

- is resistant to normal mechanical stress
- has a rough structured surface

Bumper covered with a combination of strengthening fibre and PUR

- is resistant to heavy mechanical stress
- has a rough structured surface

Bumper with rubberised fabric covering

- good to very good resistance against acids, caustic solutions, petrol and oil
- has a rough structured surface

We can supply special technical solutions for applications in damp areas. On request your special requirements will be evaluated.

Bumper Types

Outer Skin	Cable	Terminating Resistor	Type
PUR weaved	1x	Yes	ESB-11
Polyester strengthening fibre additional PUR weaved	1x	Yes	ESB-12
Rubberised fabric S 120	1x	Yes	ESB-13
PUR weaved	2x	No	ESB-21
Polyester strengthening fibre additional PUR weaved	2x	No	ESB-22
Rubberised fabric S 120	2x	No	ESB-23
PUR weaved	1x	No	ESB-31
Polyester strengthening fibre additional PUR weaved	1x	No	ESB-32
Rubberised fabric S 120	1x	No	ESB-33

Repairs

Mechanically damaged Safety Bumpers can be repaired quite simply by cleaning the damaged area with thinners and repainting with PUR.

Dimension Details

The dimensions of a Safety Bumper is limited by production facilities, function and weight.

- Maximum dimensions: Length 2m, 0.5m wide.
- Minimum dimensions: Length 0.2m, 0.1m wide.
- Bumpers with larger dimensions must be clarified by our technical department.

In order to guarantee the stability of the bumper, the ratio width/height must not exceed 1:2.5.

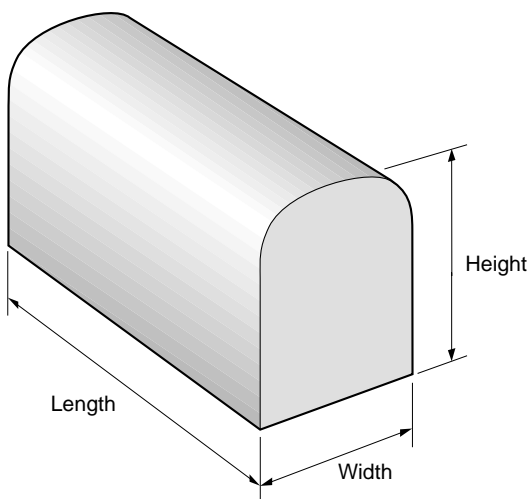

Shapes and Construction

Normally any shape can be manufactured. This allows the general look and functionality to be considered in the design.

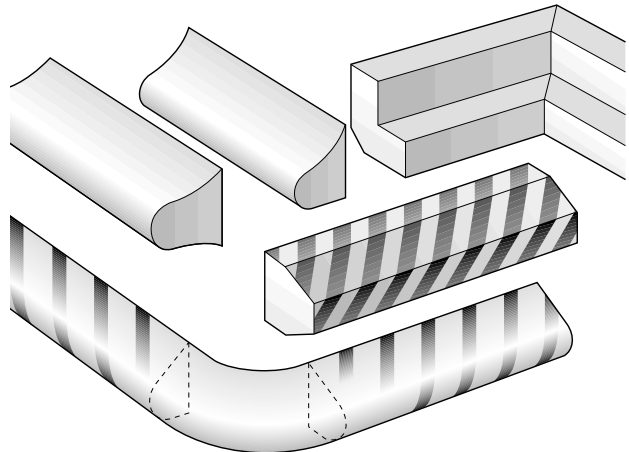

Types of Mounting

The bumpers can be mounted as follows:

- M3, M4, M5, M6 or M8 screws according to choice.
- Standard drilling template or to customer requirements (not smaller than 60mm).
- Special customer mounting requirements can also be realised.

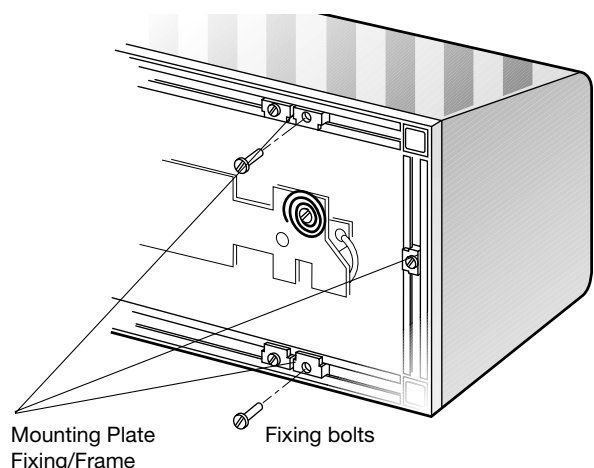

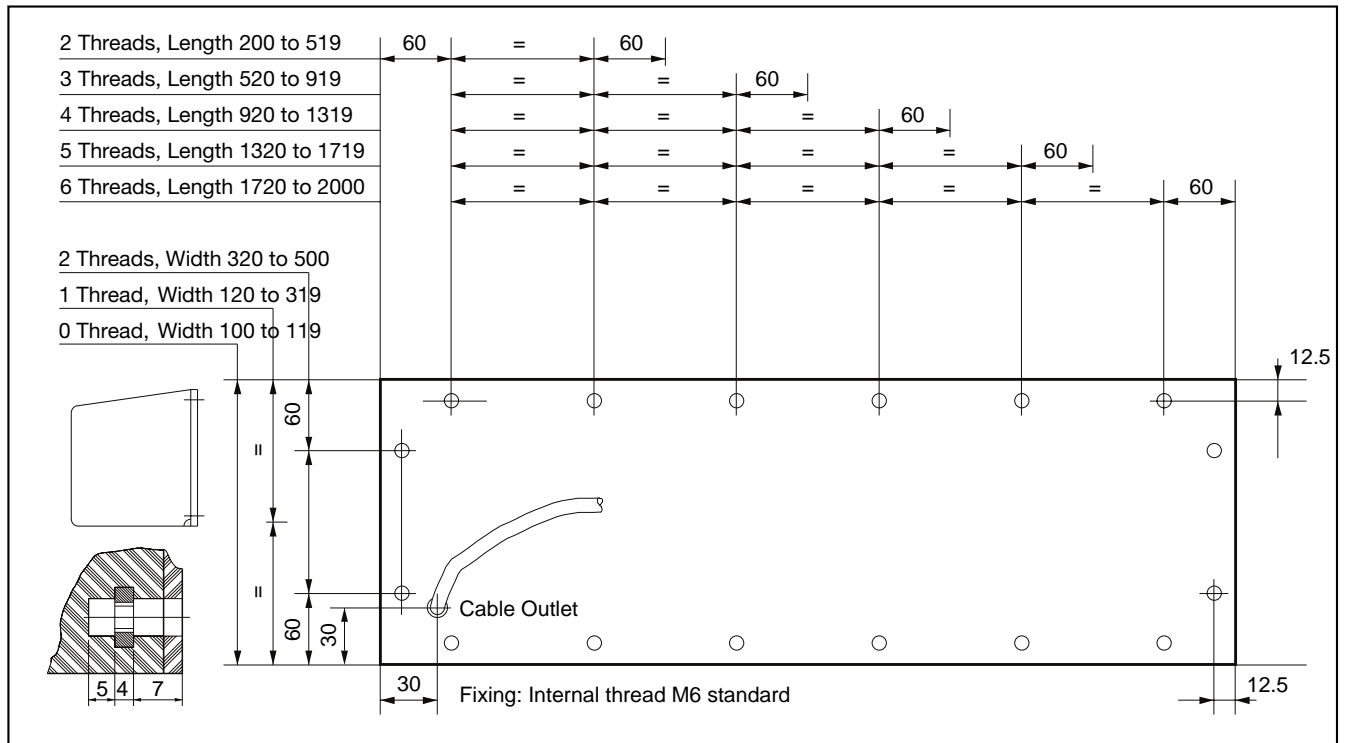

Additional Mounting Standard

The standard fixing can be varied as follows:

- Fixing M3, M4, M5, M8 threads.
- Distance from edge «a» 60mm.
- Mounting hole pitch as required.
- Cable outlet (larger or equal) 30mm as required.



Details of installation and operation can be obtained from the Assembly and Operating Instructions enclosed with the product.

Special Mountings

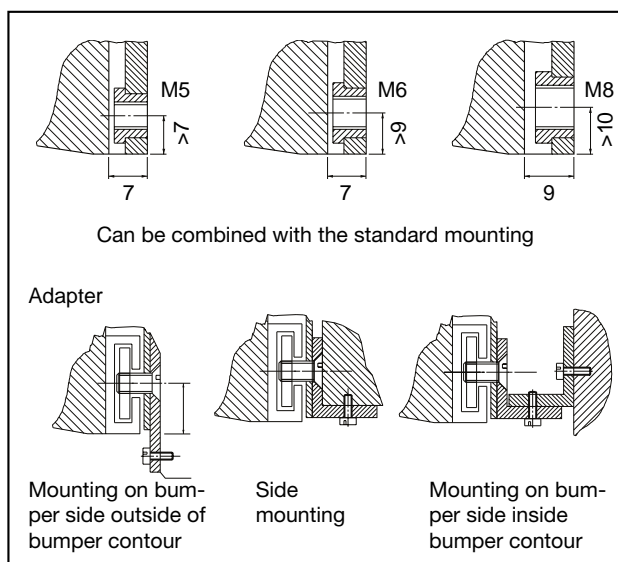

Operating Travel/Deformation Travel

The maximum load required to obtain the total deformation travel, must not exceed 250N.

Measured with a 80mm diameter test piece.

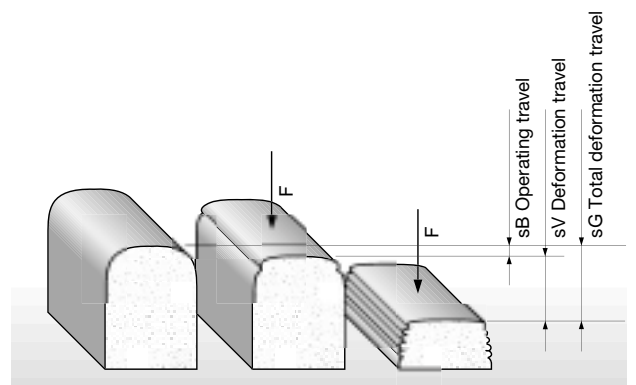

Diagram for the Calculation of Bumper Dimensions

Height (Main activating direction)	
Speed of movement	v _____ m/s
Bumper operating travel	40mm
Response travel of ES-System	v x 0,02s _____ mm
Response travel AGV-control	
v x response time of control	_____ mm
Maximum braking distance	s _____ mm
Total deformation travel	<u>sG _____ mm</u>
Collapsible zone or	
Total deformation travel	sG _____ mm
50 % of sG (part which can not be deformed)	<u>_____ mm</u>
Ideal total height of bumper	<u>_____ mm</u>

Connection and Wiring Possibilities

The switching elements in the bumper consist of one or more switching strips which are connected in series, to guarantee the safety function. The last switching strip has a termination resistor of 8kOhm.

The following should be noted:

- Max. cable length 25m.
- Cable cross-sectional area must not be less than 2x0.5mm².

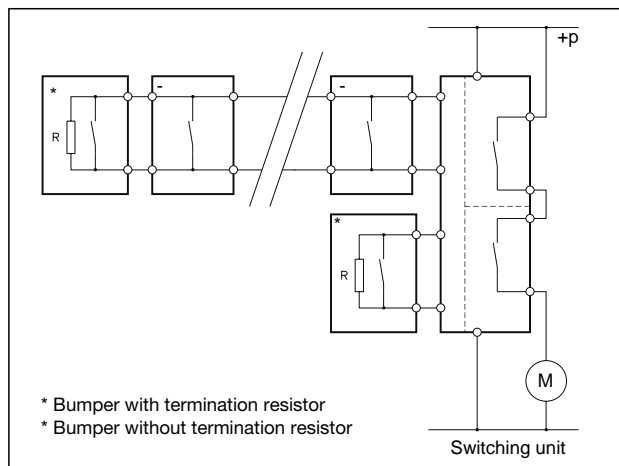

For the safety evaluation, Bircher ESR-Switching Units with 2 input channels, are used.

Technical Data

Dimensions/Size Dependent on customer (see Text)
however maximum
LxWxH 0.6x0.5x2m

Weight dependent on size (0.5x0.2x1.0m)
= approx. 7kg)

Materials

- Core PUR-polyurethane-foam
- External Skin ESB-.1: PUR weaved (standard)
ESB-.2: polyester-strengthening fibre with PUR weaved cover
ESB-.3: rubberised fabric
S-120 resistant against acids and solvents

Mounting Plate 3mm thick aluminium

Endurance	PUR-Paint	S-120
Weather, ozone	good	very good
Oils, Petrol	good	good
Solvents	sufficient	very good
Diluted Acids	good	very good
Hydrolysis	sufficient >50°C: not good	very good

Temperature Range -20°C to +65°C

Switching Elements actuated >0.5Ohm
non-actuated -8.2kOhm ±10%
(ESB-1)
->100kOhm (ESB-2./3.)

Connecting Cable 2x0.34mm², type «DM»
(VDE Li-YY, PVC-grey, Ø4.5mm)

Cable Length 2 metres long standard, can be extended in metre lengths

Connecting Plug according to customers requirements

Composition >1% share of weight
PUR-Foam (Bumper body)
PUR-Paint (Bumper skin)
Polyethylene (Strengthening fibre)
Aluminium or Steel (Base plate)
PVC (Cable sleeve)
Copper (Contact surface, cable)

Strengthening Fibre

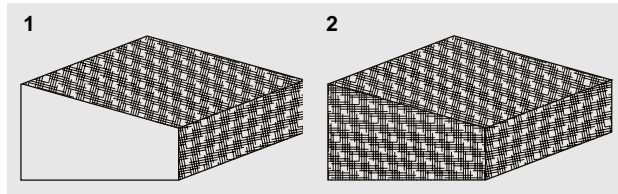

Shape

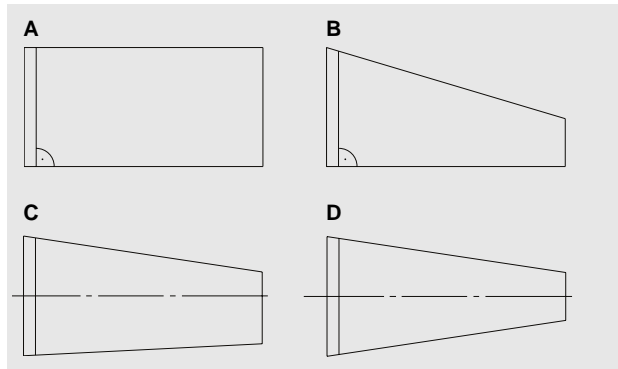

Stripes

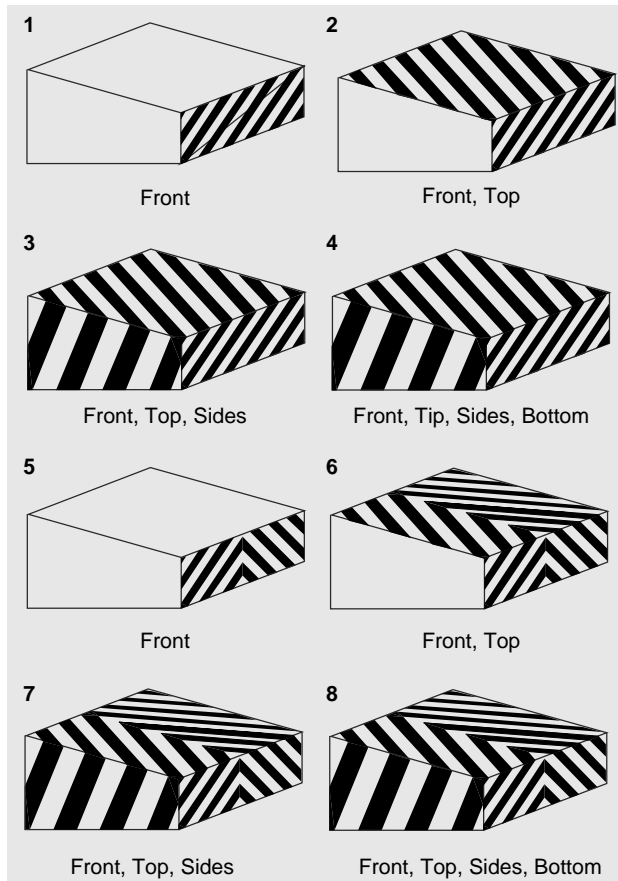

Order Information

ESB 12 1 A 1

Base Types _____

1 = 1 cable, 1 resistor
2 = 2 cables
3 = 1 cable without resistor

Covering _____

1 = PUR
2 = PUR, strengthening fibre
3 = rubberised fabric

Strengthening Fibre _____

0, 1, 2 (0 = no fibre)

Shape _____

A, B, C, D

Stripes _____

1-8 (0 = no stripes)

Quotation and Order Information

To allow a structured and efficient development of your enquiry, please complete the Diagram for the Calculation of Bumper Dimensions. Our sales team are at your disposal at all times.

Additional Order Information

- Dimensions in mm, length x width x height.
- Cable outlet.
- Mounting.
- Dimension drawing.

Special Designs

- Covering with increased resistance against aggressive mediums (rubberised fabric).
- Angle bumper.
- Special shapes (cutouts etc.).
- Other colours.

Please contact us with any questions concerning your special designs.

Safety-Bumper



ESB-41, -51, -61

- Available in almost every imaginable shape
- Extremely responsive

Safety Bumper

The purpose of Safety Bumpers is the prevention of damage caused by collisions between automatic guided vehicles (AVG's) and persons or objects. This is accomplished

- by immediate braking of the vehicle.
- by a soft collapsible zone on the bumper itself.

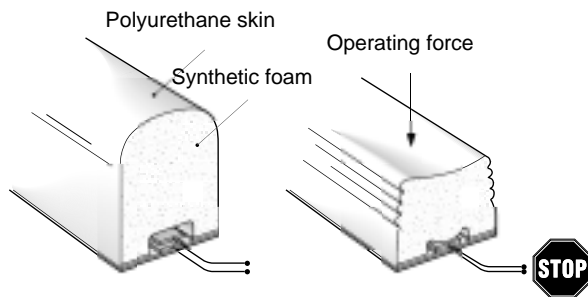

Construction

The safety bumper core consists of :

- a synthetic foam block, manufactured to shape and covered.
- switching elements
- base plate

Covering

Generally bumpers are applied in dry environments and have the following characteristics:

- resistant against normal mechanical influences.
- the surface texture is roughly structured.

Selection of Safety Bumpers

Outer Skin	Cable	Termination Resister	Type
PUR weaved	1x	Yes	ESB-41
PUR weaved	2x	No	ESB-51
PUR weaved	1x	No	ESB-61

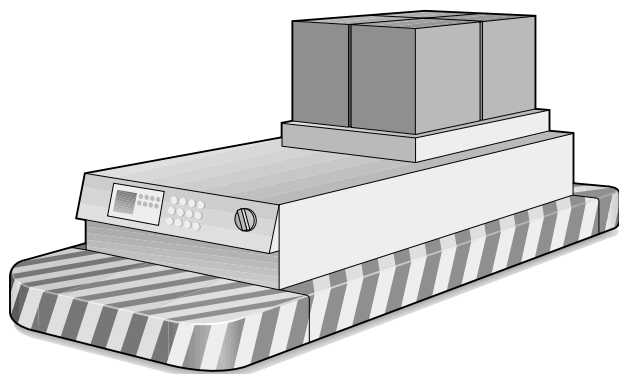

Function

The synthetic foam core is deformed by a light force on the outer bumper skin.

- two separated contact surfaces in the switching element touch each other.
- the built-in resistance falls below the defined value of 8,2kOhm.
- the switching unit evaluates the contact.

The reaction pressure is set ex-works and can not be changed.

Colours

Basically BIRCHER Safety Bumpers are delivered in yellow (RAL 1021). On request Safety Bumpers can be manufactured in other colours as well as striped.

Dimension Details

The dimensions of a Safety Bumper is limited by production facilities, function and weight.

- Maximum Dimensions 2m long, 0,5m wide
- Minimum Dimensions 0.2m long, 0.1m wide
- Larger dimensions require technical clarification.

In order to guarantee the stability of the bumper, the ratio width/height must not exceed 1:2.5

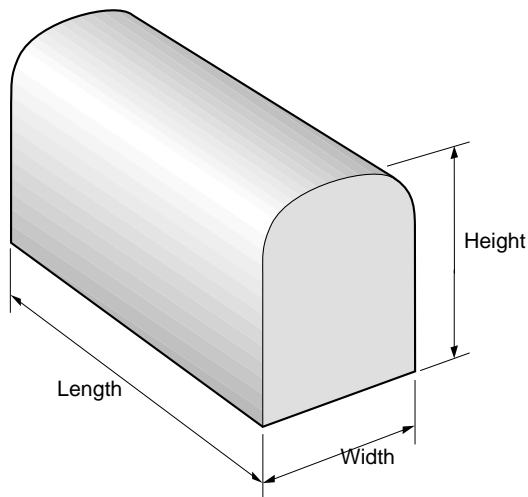

Diagram for the Calculation of Bumper Dimensions

Height (Main activating direction)

Speed of movement: v _____ m/s
 Bumper operating travel: 40mm
 Response travel of ES-System: $v \times 0,02s$ _____ mm
 Response travel AGV-control: _____ mm
 $v \times$ response time of controls _____ mm
 Maximum braking distance s _____ mm
 Total deformation travel sG _____ mm

Collapsible zone or

Total deformation travel sG _____ mm
 50% of sG (part which can not be deformed) _____ mm

Ideal total height of bumper _____ mm

Shapes and Construction

Almost any shape can be manufactured. Therefore a pleasing image and the functionality can be considered in the design.

Mounting

The bumpers can be mounted in the following way:

- M6 screws
- Standard drilling template or to customer requirements
- Other mounting possibilities according to customers wishes

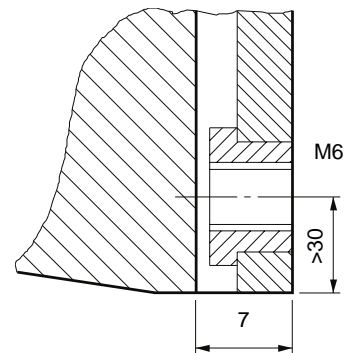

Additional Standard Mountings

The standard mounting can be varied as follows:

- M3, M4, M5 or M8 threads
- Distance from edge (larger or equal) 60mm
- Pitch of holes as required
- Cable output (larger or equal) 30mm as required



Detailed assembly and operating information can be obtained from the enclosed Assembly and Operating Manual

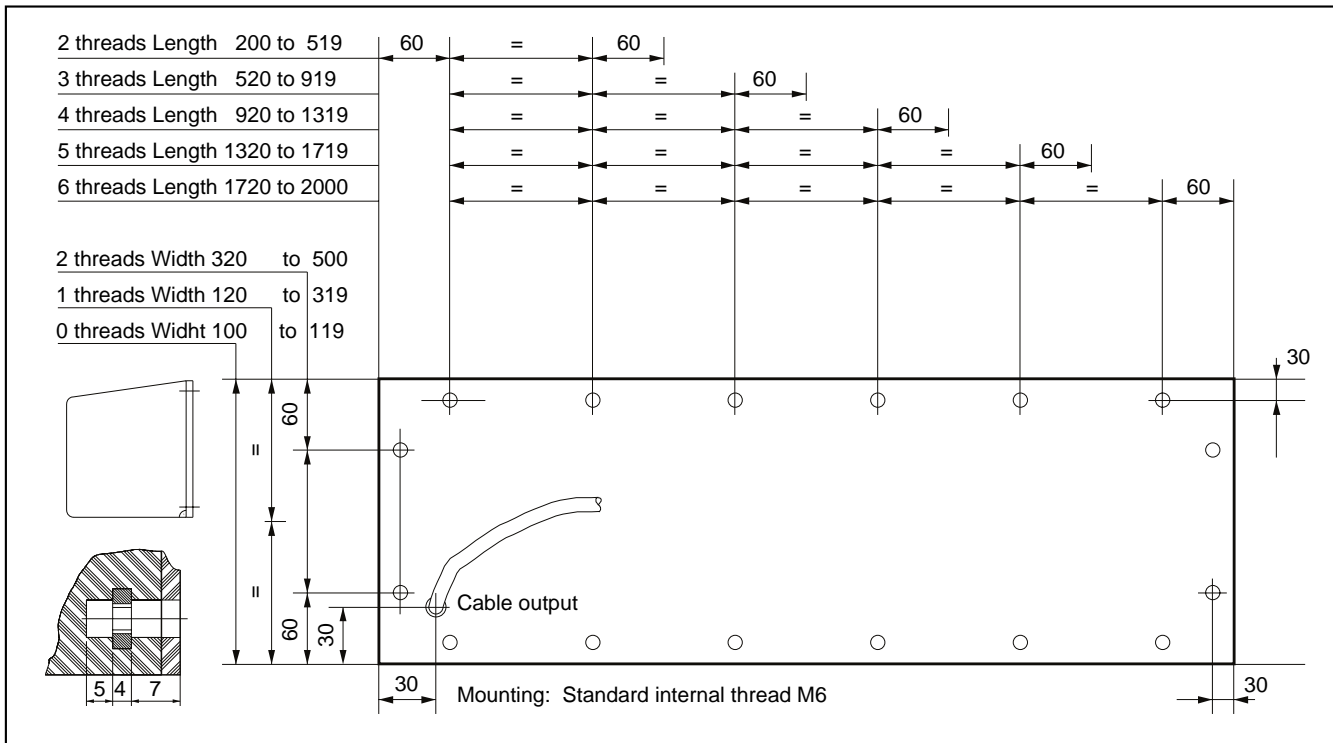

= means: same distance

Connection and Wiring Possibilities

Bumpers contain a switching strip which has a termination resistor of 8.2kOhm.

The following is to be observed:

- max. cable length 25m
- cross-sectional area of the cable must not exceed 2x0.34mm

Operating Travel/Deformation Travel

The maximum load required to obtain the total deformation travel, must not exceed 250N.

This is measured with a 80mm diameter test piece.

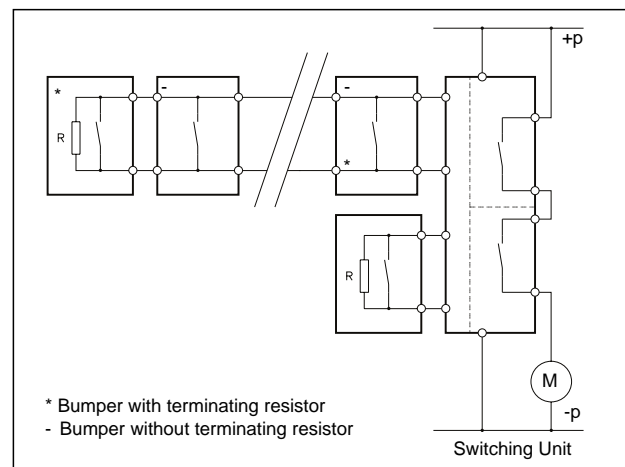
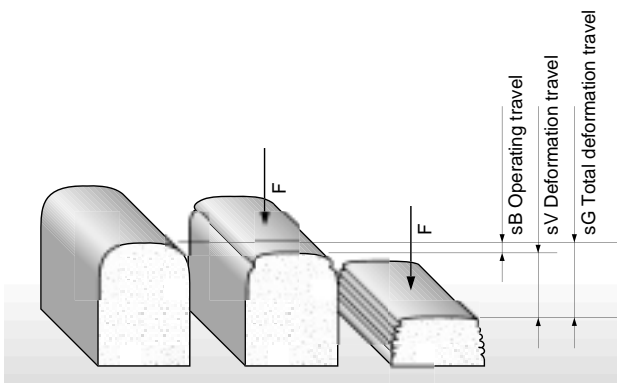

To guarantee a sure evaluation standard Bircher ESR/ESD Switching Units with two input channels are used.

Technical Data

Dimensions/Size	Dependent on customer (see Text) however maximum LxWxH 0.6 x 0.5 x 2 m
Weight	Dependent on size (0.5x0.2x1.0m = approx. 6 kg)
Materials	
Core	PUR-polyurethane-foam
External Skin	PUR weaved (standard)
Mounting Plate	3 mm thick aluminium
Endurance PUR-Paint	
Weather, ozone	good
Oils, Petrol	good
Solvents	sufficient
Diluted Acids	good
Hydrolysis	sufficient >50°C: not good
Temperature Range	-20°C to +65°C
Switching Elements	actuated >0.5 Ohm nonactuated 8.2 kOhm +/- 10% (ESB-4) >100 kOhm (ESB- 5, -6)
Connecting Cable	2x0.34mm ² , type «DM» (VDE Li-YY, PVC-grey, Ø4.5mm)
Cable Length	2 metres long standard, can be extended in metre lengths
Connecting Plug	according to customers require- ments
Composition	>1% share of weight PUR-Foam (Bumper body) PUR-Paint (Bumper skin) Polyethylene
Aluminium (Base plate)	PVC (Cable cover)

Alterations which serve to improve the product are excluded

Form

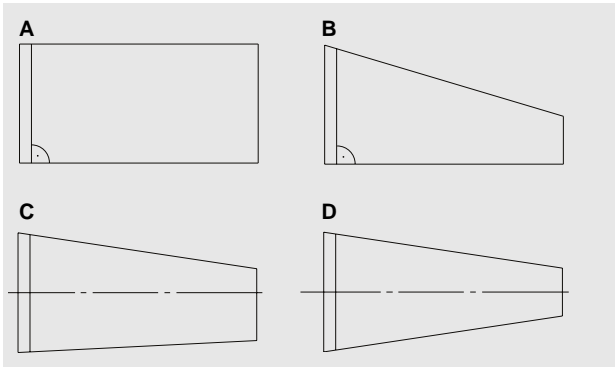

Stripes

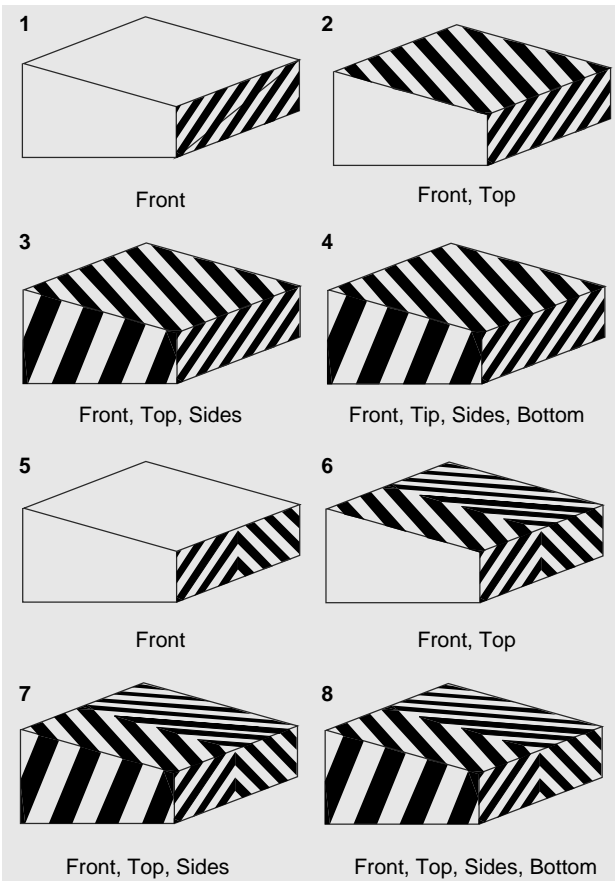

Order Information

	ESB 410 A 0
Basic Types _____	_____
4= 1 Cable, 1 Resistance	_____
5= 2 Cables	_____
6= 1 Cable, without resistance	_____
Cover _____	_____
10 = PUR	_____
Shape _____	_____
A, B, C, D	_____
Stripes _____	_____
1-8 (0 = no stripes)	_____

Quotation and Order Information

To allow a structured and efficient development of your enquiry, please complete the Diagram for the Calculation of Bumper Dimensions. Our sales team are at your service at all times.

Additional Order Information

- Dimensions in mm Length x Width x Height
- Cable output
- Mounting
- Dimension drawing

Special Constructions

- Special shapes (cut-outs etc.)
- Other colours

For special constructions please inform us of your requirements.

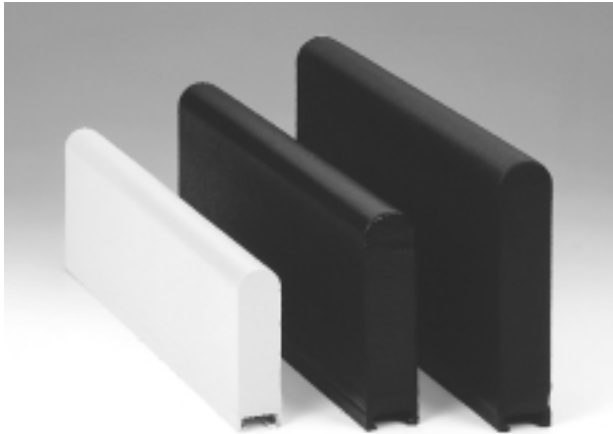

Safety Bumper

ES-BC 40/150
ES-BC 50/200
ES-BC 50/250

- Various Designs
- Extremely responsive
- Lengths up to 2 metres

Safety Bumper

The purpose of Safety Bumpers is the prevention of collisions with persons or objects and to secure edges against crushing.

This is accomplished:

- by immediate braking of the movement.
- by a soft collapsible zone on the bumper itself.

Construction

The safety bumper core consists of :

- a synthetic foam block, manufactured to shape and covered.
- switching elements
- C-rails
- Cable

Function

The synthetic foam core is deformed by a light force on the outer bumper skin.

- two separated contact surfaces in the switching element touch each other.
- the built-in resistance falls below the defined value of 8,2kOhm.
- the switching unit evaluates the contact.

The reaction pressure is set ex-works and can not be changed.

Covering

Generally bumpers are applied in dry environments and have the following characteristics:

Bumper with PUR weaved

- is resistant against normal mechanical influences.
- has a surface texture which is roughly structured.

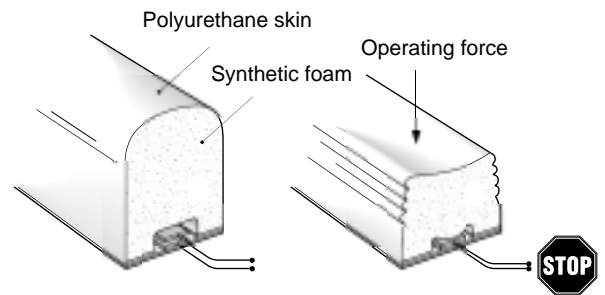

Colours

Basically BIRCHER Safety Bumpers are delivered in black. On request Safety Bumpers can be manufactured in other colours as well as striped.

Dimensions

Maximum length: 2000mm; Minimum length: 200mm

Dimension Sheet

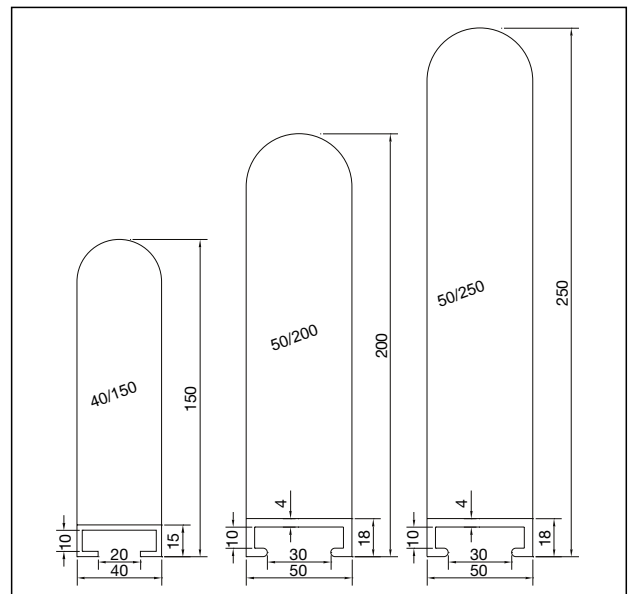

Operating Travel/Deformation Travel

The maximum load required to obtain the total deformation travel, must not exceed 250N.

This is measured with a 80mm diameter test piece.

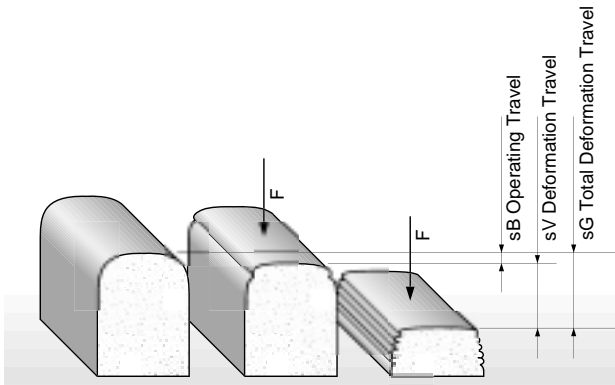

Connection and Wiring Possibilities

Bumpers contain one or more switching strips which are connected in series to guarantee the functional safety. The last switching strip has a termination resistor of 8.2kOhm.

The following is to be observed:

- max. customised length including cable 25m
- cross-sectional area of the cable must not exceed 2x0.34mm

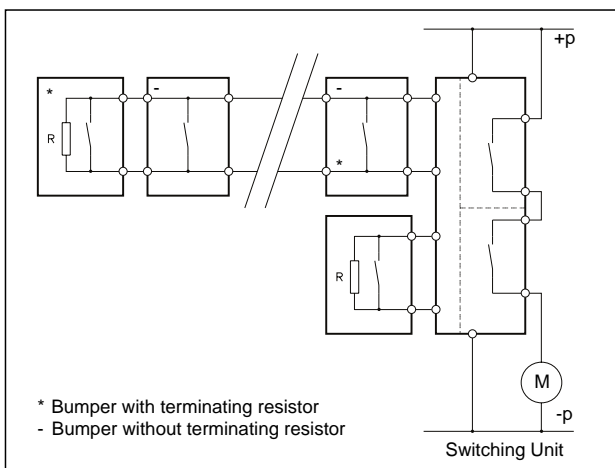

To guarantee a sure evaluation standard Bircher ESR/ESD Switching Units with two input channels are used.

Technical Data

Dimensions/Size	Dependent on customer (see Text) however maximum LxWxH 2000x50x250mm
Tolerances	(dependent on length) Up to 1000mm +/- 8mm Up to 1400mm +/- 11mm Up to 2000mm +/- 20mm
Weight	Dependent on size ES-BC 40/150 1000mm 1.5 kg ES-BC 50/200 1000mm 2.0 kg ES-BC 50/250 1000mm 2.5 kg
Materials	
Core	PUR-polyurethane-foam
External Skin	ESB-,1 PUR weaved (standard)
C-rail	Aluminium/PVC
Endurance	PUR-Paint
Weather, ozone	good
Oils, Petrol	good
Solvents	sufficient
Diluted Acids	good
Hydrolysis	sufficient >50°C: not good
Temperature Range	-20°C to +65°C
Switching Elements	actuated >0.5 Ohm nonactuated - 8.2 kOhm +/- 10% (ES-BC-1) >100 kOhm (ES-BC-2/-3)
Connecting Cable	2x0.34mm ² , type «DM» (VDE Li-YY, PVC-grey, Ø4.5mm)
Cable Length	2 metres long standard, can be extended in metre lengths
Connecting Plug	according to customers requirements
Composition	>1% share of weight PUR-Foam (Bumper body) PUR-Paint (Bumper skin) Aluminium/PVC PVC (Cable cover) Copper (contact surfaces, cable)



Detailed assembly and operating information can be obtained from the enclosed Assembly and Operating Manual

Selection Table

Height	Width	Force	Overrun	1 Cable, 1 Resistor	2 Cables	1 Cable	Model
150	40	250 N	70mm	x			ES-BC 40/150/1
150	40	250 N	70mm		x		ES-BC 40/150/2
150	40	250 N	70mm			x	ES-BC 40/150/3
200	50	250 N	110mm	x			ES-BC 50/200/1
200	50	250 N	110mm		x		ES-BC 50/200/2
200	50	250 N	110mm			x	ES-BC 50/200/3
250	50	250 N	140mm	x			ES-BC 50/250/1
250	50	250 N	140mm		x		ES-BC 50/250/2
250	50	250 N	140mm			x	ES-BC 50/250/3

Additional Order Information

- Length in mm
- Cable output
- Mounting
- Dimension drawing

Special Constructions

- Special shapes
- Other colours
- Bending radius
- Stripes

Alterations which serve to improve the product are excluded.

Order Information

ES-BC 40/150/1 1350 mm

Type _____

Dimension _____

1 = 1 Cable, with resistance _____

2 = 2 cables _____

3 = 1 cable without resistance _____

Length in mm _____
(max. 2000mm; min. 200mm)



**INDUSTRIAL
SAFETY SALES INC.**

P.O. Box 126 -- 4112 Sheridan Road
Kenosha, WI 53141
Fax: (262) 652-1388
E-mail: safetysensing@earthlink.net

(262) 652-8660