

ESD, ESR, ESA, ESP, ESQ



WORLD OF SENSORIC WORLD OF SENSORIC

## Switching Units





## Switching Units

### ESD3

- DIN Housing
- Safety Category 3 according EN954-1
- For contact mats acc. to EN 1760-1 / for safety edges acc. to EN 1760-2
- Auto, External Reset

Switching Units monitor tactile signal sensors such as safety mats, contact strips and bumper systems

### Function

Connected Sensors have a terminal resistance of 8.2 kOhm and are monitored for changes in the continuously flowing no-load current. In the non-activated condition both relays are energised.

When one or more Sensors are activated

- the total resistance sinks towards zero ohm
- if the value falls below the defined threshold (6.2 kOhm)
- the relays are de-energised
- the **yellow** LED illuminates

When a Error occurs in the Sensor circuit

- the total resistance rises towards infinity if the value rises above the defined threshold (11 kOhm)
- the relays are de-energised
- the **red** LED illuminates

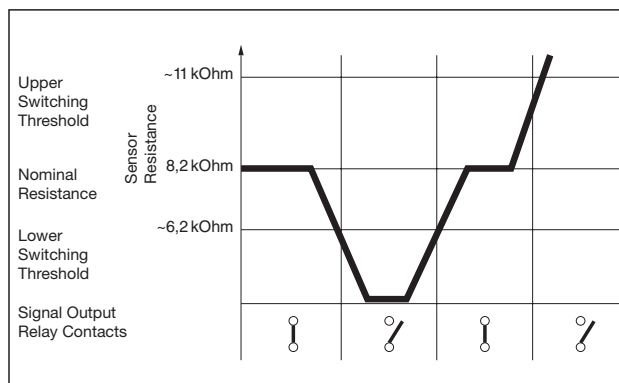

### Type ESD-3

- safety Category 3 according to EN954-1
- self-monitoring
- double redundant signal evaluation
- automatic or external Reset
- fail-safe
- force guided relay

### Block Diagram and Connection

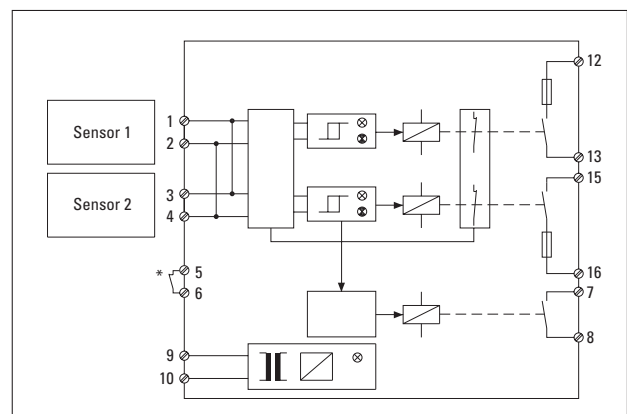

Terminal		Terminal	
1	Signal Sensor 1	9	Supply Voltage
2	Signal Sensor 1	10	Supply Voltage
3	Signal Sensor 2	11	–
4	Signal Sensor 2	12	Safety Output Relay 1
5	External Reset	13	Safety Output Relay 1
6	External Reset	14	–
7	Indication Relay	15	Safety Output Relay 2
8	Indication Relay	16	Safety Output Relay 2

\* Versions with automatic reset have this function integrated in the circuit

### Terminals

- type: 2 x 8 pole plugable
- max. cross-section 2.5 mm<sup>2</sup>

## Variation Table

The ESD3 variants are distinguished firstly by their reset function and secondly by the configuration of the status relay contact. This can be implemented off-load both as open and closed. It is not a safety contact, but is exclusively used for transmitting information. It is not monitored for failure and must never be used for safety shutdown in any form whatsoever. Each type is available in three voltage supply variants: 24 V AC/DC, 115 V AC, 230 V AC.

Version	Inputs 2	Safety Relay Separation	Reset		Status Relay			
			Auto	External	M	SM	C	D
03	x	x	x			x		
04	x	x	x		x			
05	x	x		x		x		
06	x	x		x	x			
08	x	x	x					x
09	x	x		x				x
03C	x	x	x					x
05C	x	x		x				x

## Function Status Relay

Contacts	Type	No voltage	Sensor not operated	Sensor operated (LED yellow)	Error (LED red)
Safety contact	all Types	O	X	O	O
Error Indication contact SM	ESD3-03,-05	O	X	X	O
Error Indication contact C	ESD3-03C,-05C	X	O	O	X
Indication contact M	ESD3-04,-06	O	X	O	O
Indication contact D	ESD3-08,-09	X	O	X	X

Legend:

O = Contact open

X = Contact closed

## Reset

Auto-Reset

- NO button on the front
- Reset electronically integrated

External Reset

- NO button on the front
- external button (NC)
- Terminals 5,6

## Technical data

- Housing DIN ABS, red/black
- Isolation Class IP 30 (IEC 529)
- Protection Class IP54
- Weight max. 250 gramm (depending on type)
- Power Supply 24 VACDC  $\pm 10\%$
- acc. to EN60204-1 115 VAC  $\pm 10\%$
- (depending on type) 230 VAC  $\pm 10\%$
- Frequency Range 50/60 Hz (45–66 Hz)
- Power consumption max. 5 VA
- Duty Cycle 100%
- Fastening 35 mm mounting rail acc. to EN50022

## Safety Output Relay

- Utilization category AC-1: 250 V/2 A/500 VA  
acc. to EN60947-4-1\* approx. 300'000 switchings
- DC-1: 24V/2 A/48 W  
approx. 700'000 switchings
- Utilization category AC-15: 250 V/2 A/500 VA  
acc. to EN60947-5-1\* approx. 130'000 switchings
- (DC13: 6 switchings/ DC-13: 24V/2 A/48 W  
minute) approx. 70'000 switchings
- Contacts positively driven relays, AgCuNi
- Operating Life Mechanical 50 million switchings
- Fuse Protection 2 A slow

## Error Signal Indicator Relay

- Switching Capacity 24 VDC/1 A, resistive load  
30 VAC/1 A, resistive load

## Indicators

- Operation LED 3 mm  
Green
- Error Red (sensor resp. system error)
- Safety Switch-off Yellow (sensor)

## Reaction Time

- Sensor relay < 50 ms

## Temperature Range

- Operation  $-20^{\circ}\text{C}$  to  $+55^{\circ}\text{C}$
- Storage  $-20^{\circ}\text{C}$  to  $+80^{\circ}\text{C}$

## Humidity

max. 80% relative  
(no condensation allowed)

**\*If not mentioned ratings are required, ask for them at the manufacturer.**

For 24 VACDC supply voltage must be obtained from a safety trafo according to IEC742. The wiring must be protected against mechanical damage.

Specifications are liable to change in accordance with product improvement.

## Dimension Sheet

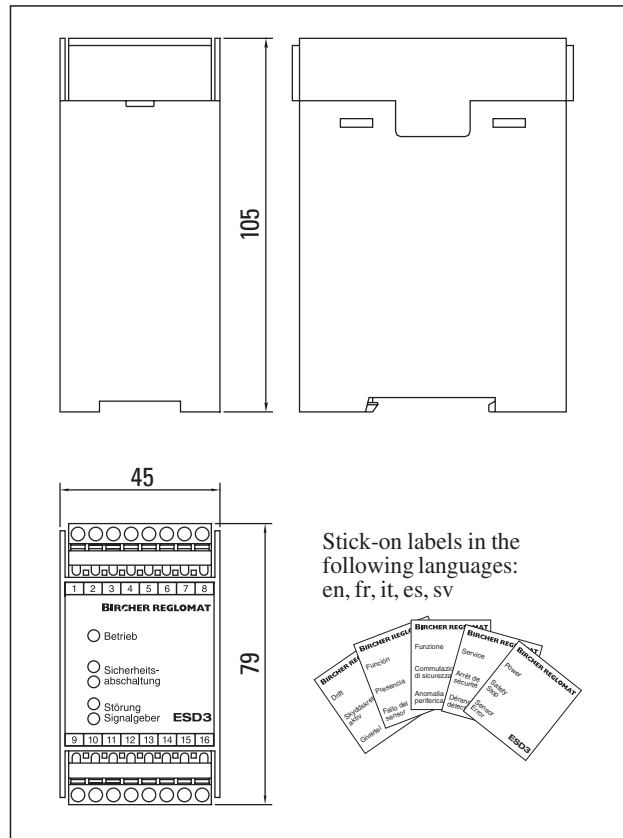

Detailed assembly and operating information can be obtained from the Operating Instructions enclosed with the product

## Order Information

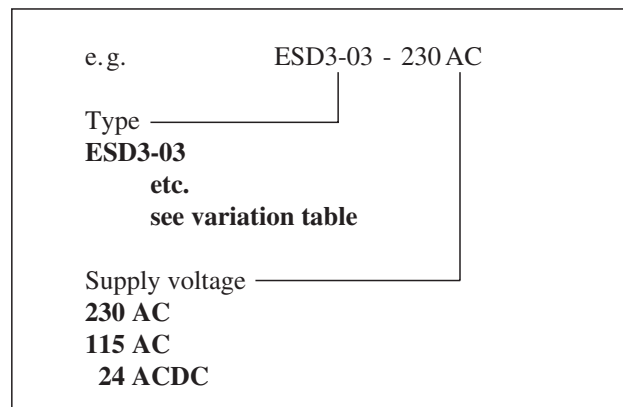



## Switching Units

### ESR-1/-3

- Safety Category 1, 3, according to CEN
- Bircher M3 Housing
- 11-pin Plug
- Large Selection

### Switching Units ESR

Connected Sensors are monitored for changes in the continuously flowing no-load current.

In the non-activated condition both relays are energised.

When one or more Sensors are activated

- the total resistance sinks towards zero ohm
- if the value falls below the defined threshold (6 kOhm)
- the relays are de-energised
- the **yellow** LED illuminates

When a Error occurs in the Sensor circuit

- the total resistance rises towards infinity
- if the value rises above the defined threshold (12 kOhm)
- the relays are de-energised
- the **red** LED illuminates

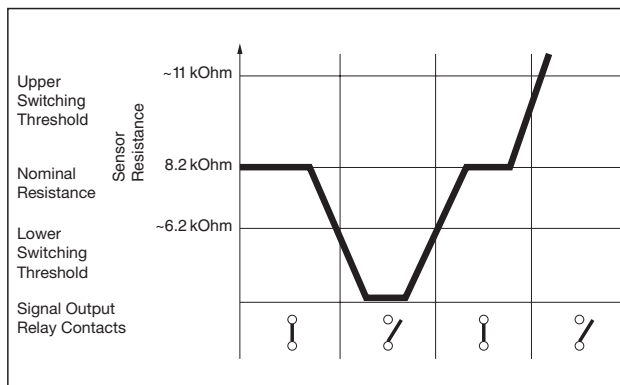

### Connection

- The maximum length of the Sensor with cable must not exceed 25 metres
- Maximum surface area 5 m<sup>2</sup>
- Multiple Sensors are to be connected in series
- The total resistance must not exceed 8.2 kOhm

### Type ESR-1

#### ESR-11

- Safety Category 1
- Two channel design
- Simple signal evaluation
- Recognition of Sensor Errors

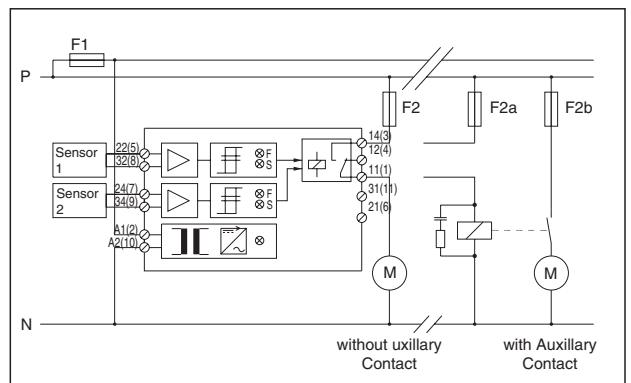

#### ESR-12

In addition to ESR-11

- Simple signal evaluation per output

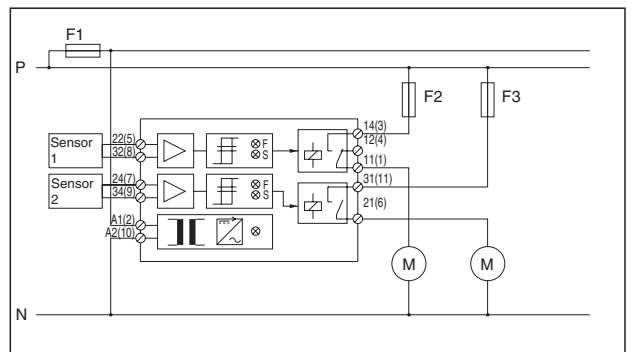

## ESR-13

In addition to ESR-11

- Error indication connection

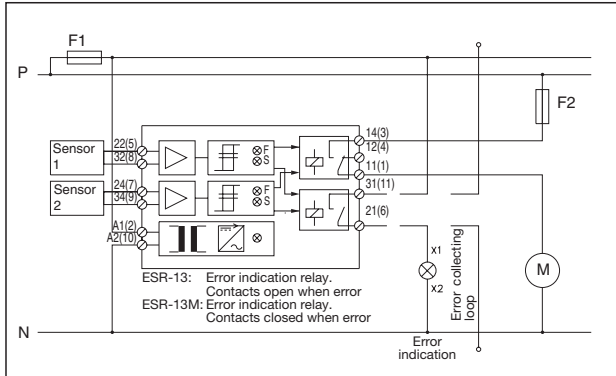

## Dimension Sheet

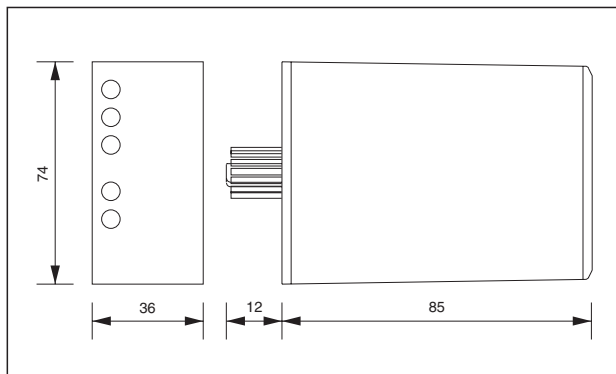

## Technical data ESR-1

Housing Type M3, Material Red Noryl  
 Isolation Class IP 30 (IEC 529)  
 Weight max. 250 gramm (depending on type)

Power Supply DC voltages are battery power only

- Type ESR-1. -24VADC 24-36VAC/24-48VDC ( $\pm 20\%$ )

- Type ESR-1. -115VAC (+10%/-20%) with isolating transformer

- Type ESR-1. -230VAC (+10%/-20%) with isolating transformer

Frequency Range 50/60 Hz (45-66 Hz)

Power consumption max. 3 VA

Duty Cycle 100% ED

Signal Output Relay/  
 Error Indication Relay

- Switching Capacity 250 VAC/5 A (ohm)

- Contact Material Hard silver

- Operating Life Mechanical 200 million

switchings

Electrical 80 000 switchings at

250 VAC/5 A

- Fuse Protection 5 A slow

Indicators LED 5 mm

- Operation Green

- Function Yellow

-Error Red

Reaction Time < 70 ms

Temperature Range

- Operation -20°C to +50°C

- Storage -20°C to +80°C

Humidity max. 80% relative

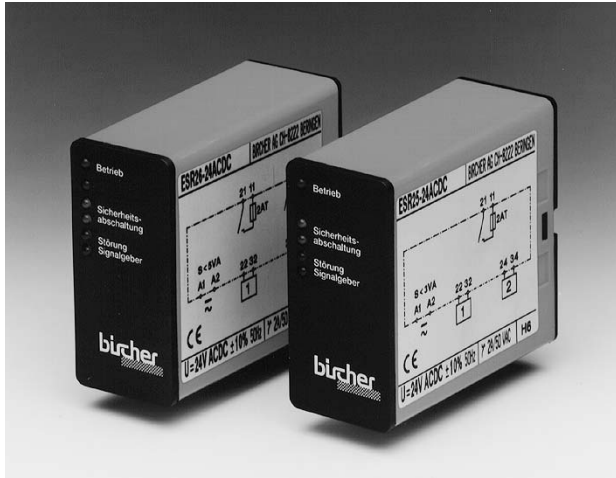

## Switching Units

### ESR25/26

- 11 Pin Pluggable Socket
- GS-BE-17 and ZH 1/494
- 1-/2-Channel

### General

The difference between the ESR25 and ESR26 is that the ESR26 has two separate evaluation circuits.

### Function

Connected sensors are monitored with a terminating resistance of 8.2 kOhm to detect changes in the constant flowing zero-signal current. Both relays are energised in the non-active condition.

If one or more sensors are activated

- the total resistance drops towards zero ohm
- when the resistance falls below the defined limit (approx. 2 kOhm)
- the relays de-energise
- the yellow LED illuminates

When a fault occurs in the sensor circuit (cable breakage, sensor defect...)

- the total resistance increases
- when the resistance exceeds the defined limit (approx. 9 kOhm)
- the relays de-energise
- the red LED illuminates

### Terminal/Connections

Terminal	ESR25	ESR26
A1,A2 (2,10)	Supply 24VACDC	Supply 24VACDC
22,32 (5,8)	Sensor-Input	Sensor-Input 1
24,34 (7,9)	Sensor-Input (or 8.2 kOhm)	Sensor-Input 2
11,21 (1,6)	Safety-Output	Safety-Output 1
12,14 (3,4)	–	Safety-Output 2
31 (11)	–	–

### Connection

- max. total length of sensor with cable 50 m
- max. total area of sensor 5 m<sup>2</sup>
- multiple sensors are connected in series
- the total resistance must not exceed 8.2 kOhm

- Important:
- The installed fuse is absolutely necessary. It protects the relay contacts against «welding» when overloaded.
  - Suppressors (220 Ohms/0.1 μF) are to be connected across the connected loads.
  - Periodical function test are to be made. The designated test contacts are to be bridged (see Layout). The applied tests are to be documented.
  - Further installation instructions can be obtained from the operators manual enclosed with the product.

## Block Diagram

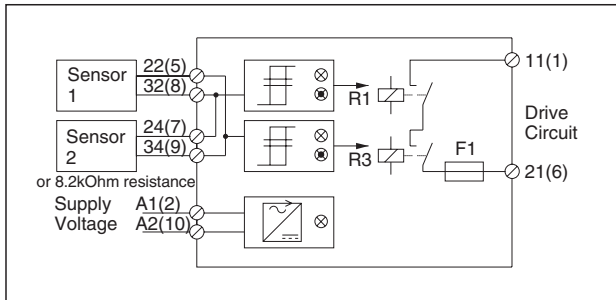

### ESR25

- two parallel sensor inputs
- safety output
- supply voltage 24VACDC
- redundant evaluation of the sensor

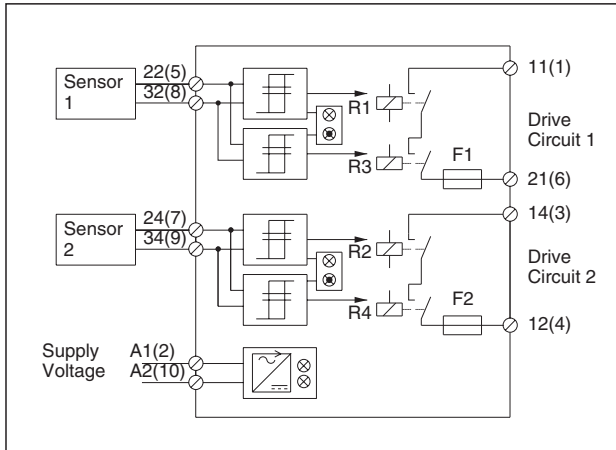

### ESR26

- two separate sensor inputs
- two separate safety outputs
- supply voltage 24VACDC
- redundant evaluation of both channels

## Technical Data

Housing	NORYL, red
Face	Black
Dimensions	85 x 74 x 36 mm
Plug-socket	11-Pin
Isolation Class	IP30
Isolation Class	IP54
Application area	
Temperature Range	-20°C +55°C
Power Supply	24 VACDC ±10%
Frequency	50/60 Hz
Power Consumption	
- ESR25	< 3 VA
- ESR26	< 5 VA
Sensor Input	<b>ESR25</b>
- Reaction Value	
«Activated»	< 2.3–2.5 kOhm
- Reaction Value	
«Interruption»	> 8.9–10.4 kOhm
Sensor Input	<b>ESR26</b>
- Reaction Value	
«Activated»	< 1.4–1.8 kOhm
- Reaction Value	
«Interruption»	> 8.6–9.3 kOhm
- Reaction Time	max. 12 ms
Signal Output Relay	2 A/50 VAC per channel
Display	LED 3 mm
- Operation	Green
- Safety Switch-off	Yellow
- Error (Interruption)	Red
Test Specifications	GS-BE-17 (April '98) and ZH 1/494 (Issue August 1994)
Overvoltage Category	II (EN 61010-1)
Contamination Grade	2 (EN 61010-1)
Protection Class	0 (EN 60730-1 and EN 60335-1)

## LED Status

Supply Voltage	Function	Green	Yellow	Red	Output
Off		☾	☾	☾	Open
On	Ready	☀	☾	☾	Close
On	One sensor activated	☀	☀	☾	Open
On	Short-circuit or Test	☀	☀	☾	Open
On	Cable breakage	☀	☾	☀	Open

## Layout

### ESR25

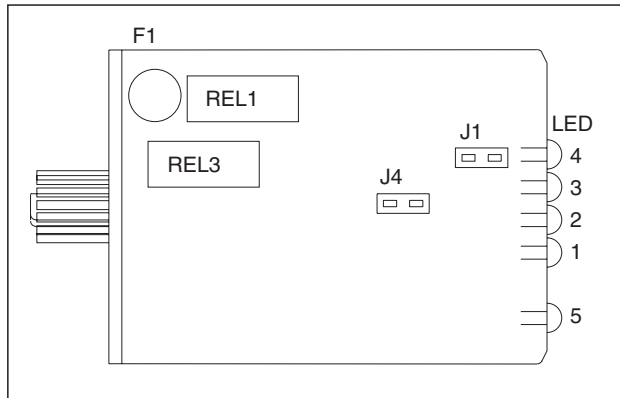

### ESR26

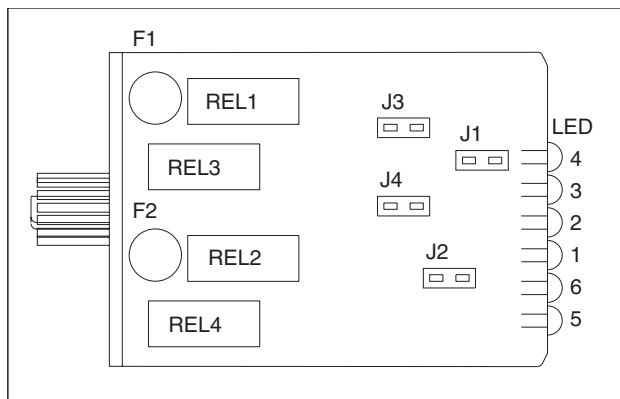

## Dimension Sheet

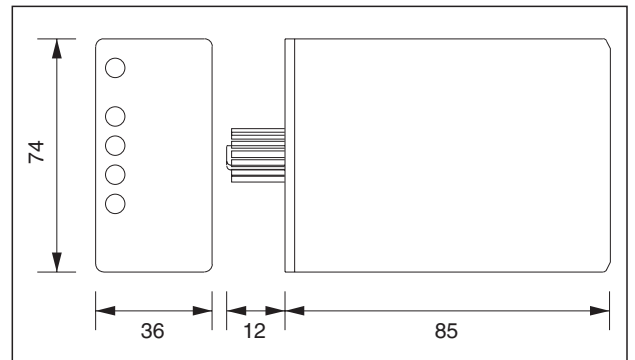

## Ordering Information

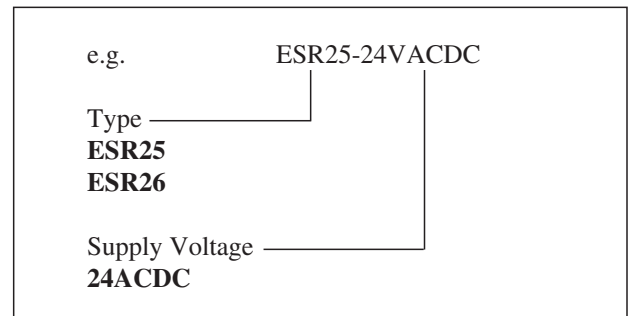

- LED5            Operation Display (green)
- LED6            Operation Display (green) (only ESR26)
- LED1, LED2    Function Display (yellow)
- LED3, LED4    Error Display (red)
- REL1, REL3    Switching Circuit 1, Working contact  
switched in series
- REL2, REL4    Switching Circuit 2, Working contact  
switched in series (only ESR26)
- F1                Fuse 2 Amp slow Relay contact protection
- F2                Fuse 2 Amp slow Relay contact protection  
(only ESR26)
- J1                Test Contact for REL1
- J2                Test Contact for REL4 (only ESR26)
- J3                Test Contact for REL2 (only ESR26)
- J4                Test Contact for REL3

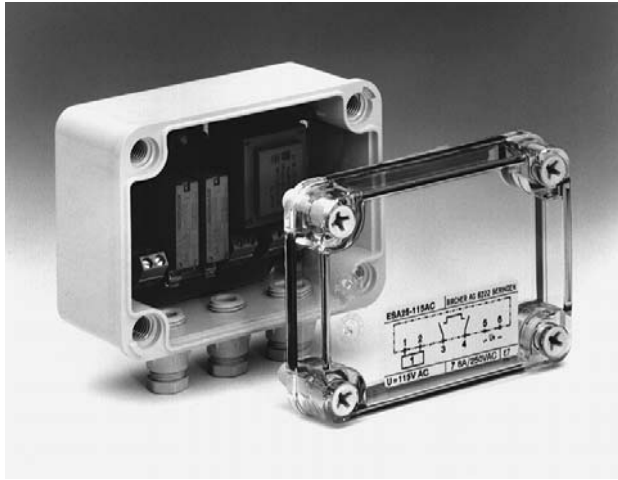

## Switching Unit

**ESA 25** (A = Installation Housing)

**ESP 25** (P = Printed Circuit Board)

- IP65 Protection Class (ESA 25)
- Installation Housing
- Redundant signal evaluation

### Switching Units ESA

Connected Sensors are monitored for changes in the continuously flowing no-load current. In the non-activated condition both relays are energised.

#### ESA 25, ESP 25

When one or more Sensors are activated

- the total resistance sinks towards zero ohm
- if the value falls below the defined threshold
- the relays are de-energised
- the yellow LED illuminates

### Wiring Diagram

For each sensor two redundant channels are available. The two output contacts are connected in series and protected with a fuse.

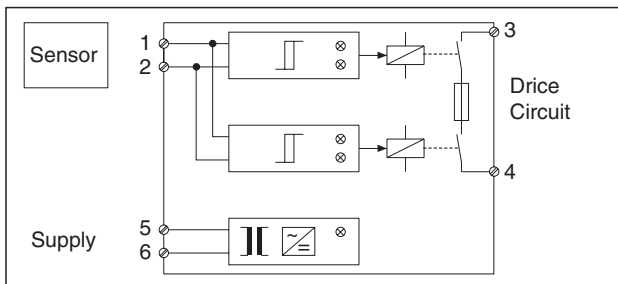

ESA 25 / ESP 25

### ESAS 25, ESPS 25 / Stop-Restart

- Basic function as ESA 25/ESP 25
- Additional when the Sensor is activated for 1 sec. the third relay contact closes for 1.5 sec. (restart)

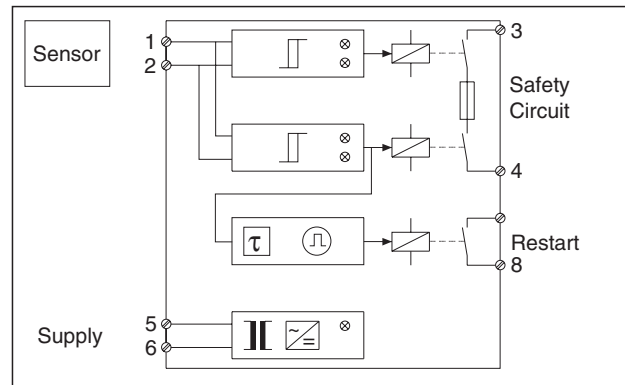
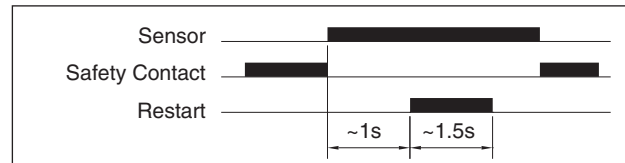

ESAS 25 / ESPS 25

## ESAT 25, ESPT 25 / Service Door

- Basic function as ESA 25/ESP 25
- Additional input for service door function
- Output for emergency stop circuit

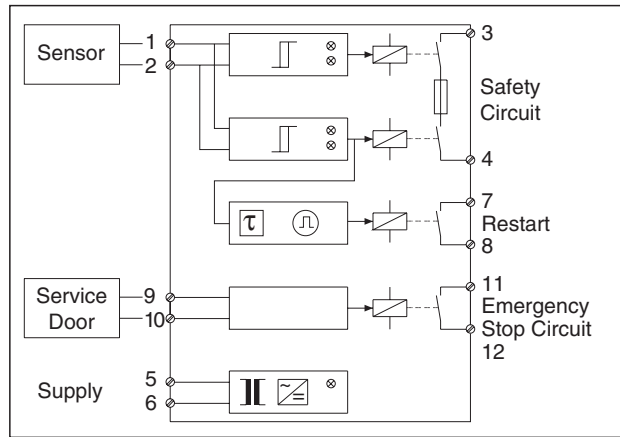

ESAT 25 / ESPT 25

## Connection

- The maximum length of the Sensor must not exceed 50 metres
- Maximum surface area 5 m<sup>2</sup>
- Multiple Sensors are to be connected in series
- The total resistance must not exceed 8.2 kOhm

### Important:

- the installed fuse is absolutely necessary
  - to protect the relay contacts from «welding» when overloaded
- Suppressors (Type 220 Ohm/0.1 µF) are to be connected across inductive loads



The assembly and operating instructions are described in the Assembly and Operating Manuals supplied with the product.

## Technical data

	ESA 25	ESP 25
Housing	ABS grey	–
	transparent cover	–
Dimensions	80 x 110 x 65	70 x 94
- Protection Class	IP65	IP00
- Cable gland	3 x PG9	–
Supply Voltage	230 VAC (+10/-20%)	
	with isolating trafo	
	115 VAC (+10/-20%)	
	with isolating trafo	
	24 VADC (+10/-10%)	
Frequency Range	50/60 Hz	
Power Consumption	max. 4 VA	
Sensor Inputs		
- Input resistance	5 kOhm to 12 V (internally)	
- Input voltage with 8.2kOhm	approx. 7.5 VDC	
Signal Output Relay		
- Switching Capacity	2 A/250 VAC	
- Reaction time	< 15 ms	
- Reaction time by interrupt	< 15 ms	
Indicators	LED 3 mm	
- Operation	Green	
- Safety Shutdown	Yellow (2 off)	
- Error (interrupt)	Red (2 off)	
Temperature Range	-20°C to 55°C	
Testing Basis	GS-BE 17 and ZH 1/494	

### Additional Data

	ESA 25	ESP 25
Function «Restart»	see ESA	
Housing		
Cable Gland	1 x PG7, 3 x PG9	–
Relay fro Restart Function		
- Switching Capacity	2A/250VAC	
- Time Delay	1...1.5sec	
- Impulse Time	1.5...2sec	

	ESAT25	ESPT25
Function «Service Door»		
Housing	PVC grey	
- Dimensions	105 x 105 x 66	94 x 94 x 32
- Protection Class	IP55	IP00
- Cable Gland	4 x PG7, 1 x PG9	–
Relay for Service Door		
- Switching Capacity	2A/250 VAC	

## Status LED

Supply	Function	Green	Yellow	Red	Output
Off	Not ready				open
On	Ready				closed
On	Sensor activated				open
On	Short-circuit or test				open
On	Cable breakage				open

## Dimension Sheets

### Installation Housing

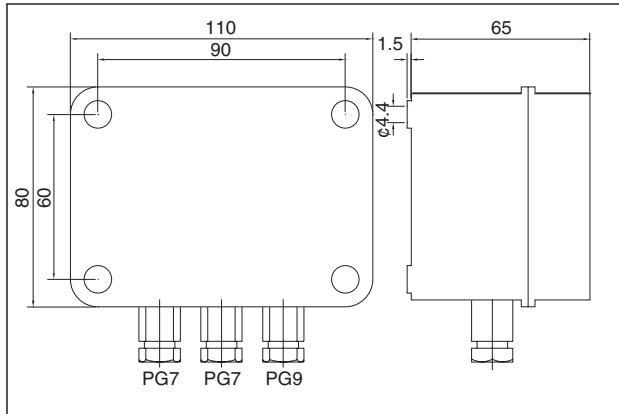

ESA 25

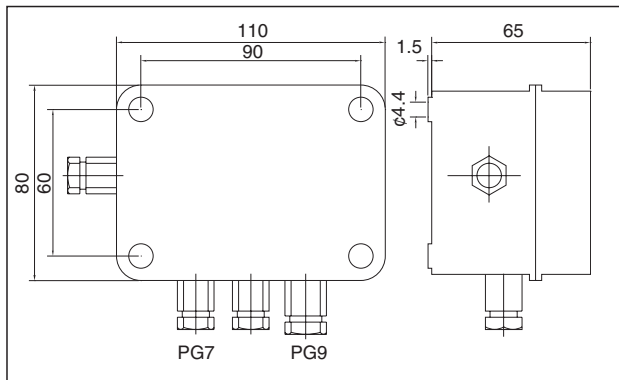

ESAS 25

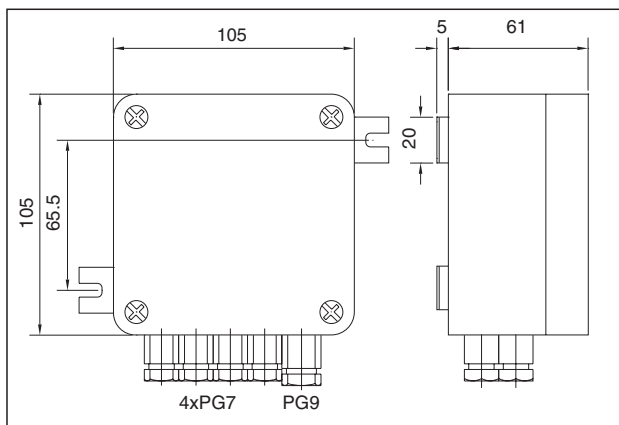

ESAT 25

## Connections, Component Layout

LED1	Operating indicator (green)
LED2, LED4	Function indicator (yellow)
LED3, LED5	Error indicator (red)
REL1, REL2	Switching circuit, working contacts switched in series
F1	Fuse 2A slow, relay contact protection
J1	Test contact for REL1
J2	Test contact for REL2

## Print Version

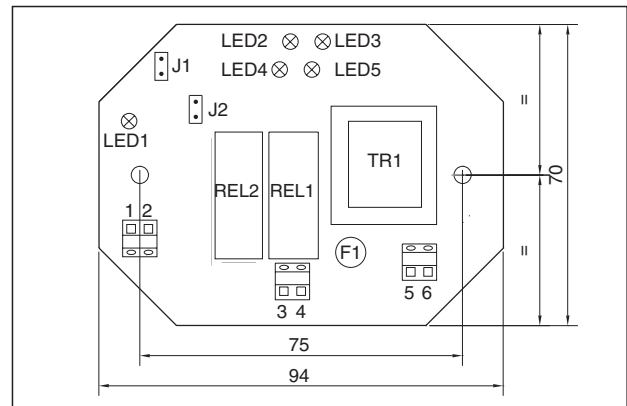

ESA/ESP

Terminals/Connection Layout:  
3,4 Safety Circuit – 5,6 Supply – 1,2 Sensor

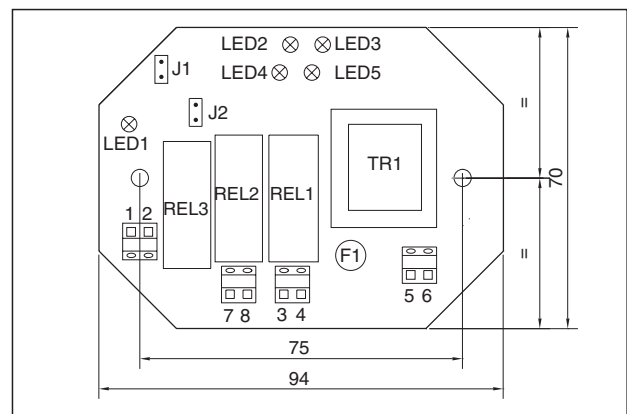

ESAS/ESPS



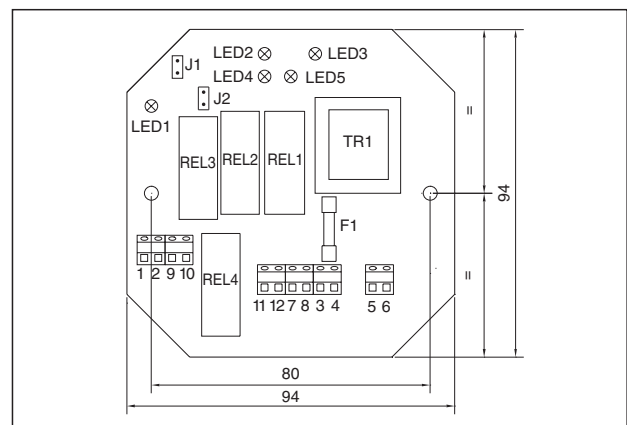

Terminals/Connection Layout:  
3,4 Safety Circuit – 7,8 Restart – 5,6 Supply – 1,2 Sensor

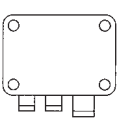
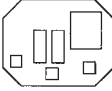
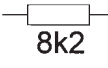
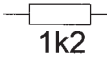

ESAS/ESPS

Terminals/Connection Layout:  
3,4 Safety Circuit – 7,8 Restart – 5,6 Supply – 1,2 Sensor  
– 9,10 Input Service Door – 11,12 Output Service Door

## Overview ESA/ESP

Total Programme							
ESA 25							
ESA 25-R							
ESA 25-D							
ESAS 25							
ESAS 25-R							
ESAS 25-D							
ESAT 25							
ESAT 25-R							
ESAT 25-D							
ESP 25							
ESP 25-R							
ESP 25-D							
ESPS 25							
ESPS 25-R							
ESPS 25-D							
ESPT 25							
ESPT 25-R							
ESPT 25-D							
ESZ-25							
ESZ-25.D							
ESZS-25							
ESZS-25-D							

## Order Information

e. g.

ESPT 25-230 AC

Type

- ESA Standard Unit
- ESP Standard Print Version
- ESAS Stop-Restart
- ESPS Stop-Restart Print Version
- ESAT Service Door
- ESPT Service Door Print Version
- ESZ plugable

Supply Voltage

- 24VADC
- 115VAC
- 230VAC



## General

The ESQ is a electronic switching unit of the ES family. It controls sensors to a zero-signal current.

## Function

Connected sensors are monitored with a terminating resistance of 8.2 kOhm to detect changes in the constant flowing zero-signal current. All relays are energised in the non active condition.

If one or more sensors are activated

- the total resistance of the sensor system drops towards zero ohm
- the resistance falls below the defined limit (1.5 kOhm)
- the safety relay de-energises
- the appropriate service relay de-energises (no safety output)
- the yellow LED illuminates according to the illustration «Status LED»

When a fault occurs in a sensor circuite (cable breakage, sensor defect...)

- the total resistance of the appropriate sensor system increases
- the resistance exceeds the defined limit (9 kOhm)
- the safety relay de-energises
- the appropriate service relay de-energises (no safety output)
- the red LED illuminates according to the illustration «Status LED»

## Switching Units

### ESQ

- GS-BE17 and ZH 1/494
- 4-channel
- Housing IP65
- Redundant evaluation

## Connection

- max. total length of one sensor system with cable 50 m
- max. total area of one sensor system 5 m<sup>2</sup>
- multiple sensors are connected in series
- the total resistance must not exceed 8.2 kOhm

## Important

- the installed fuse is absolutely necessary. It protects the relay contacts against «welding» when overloaded.
- Suppressors (220 Ohms/0.1 µF) are to be connected across the inductive loads.
- Periodical function tests are to be made (see Assembly, Commissioning, Periodical Tests)

## Status LED

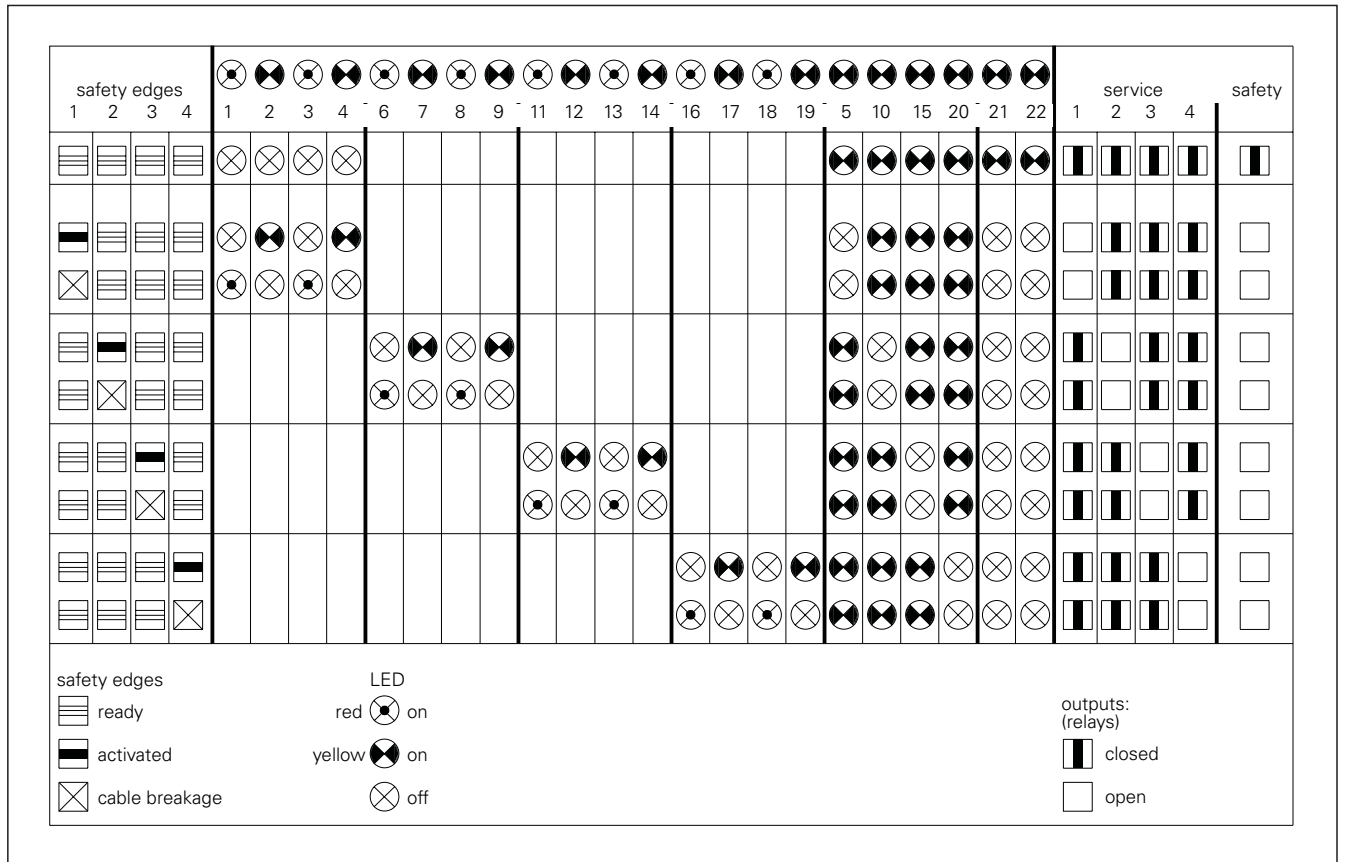

## Terminal/Connections

1,2	Sensor-Input 1
3,4	Sensor-Input 2
5,6	Sensor-Input 3
7,8	Sensor-Input 4
9,10	Supply 24VACDC
11,12	Service-Output 1
13,14	Service-Output 2
15,16	Service-Output 3
17,18	Service-Output 4
19,20	Safety-Output

## Block Diagram

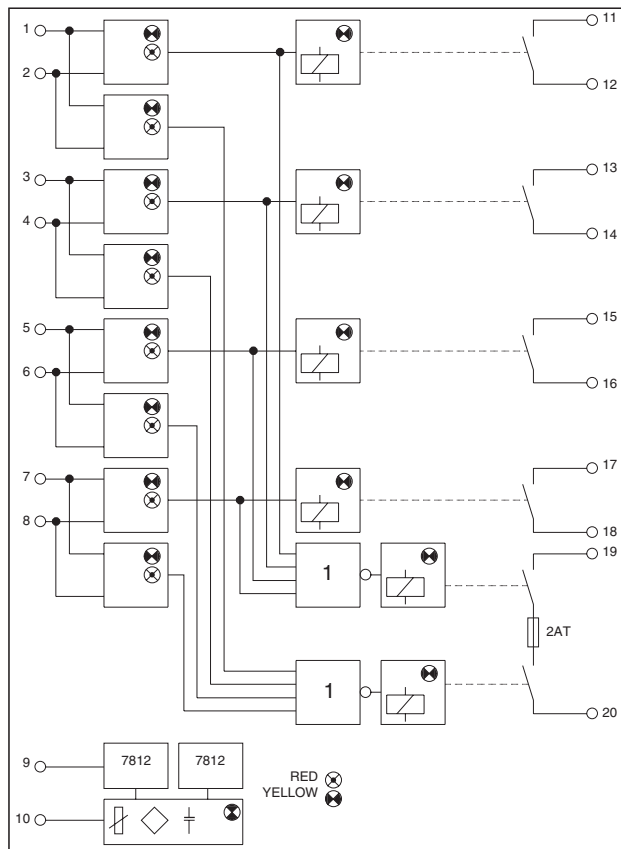

- four parallel sensor inputs
- one safety output
- four service outputs
- supply 24VACDC
- redundant evaluation of sensors

## Technical Data

Housing	ABS, gray, cover transparent
Dimensions	120 x 200 x 75 mm
Isolation Class	IP65
Temperature Range	-20°C to 55°C
Power Supply	24 VACDC ±10%
Frequency	50/60 Hz
Power Consumption	< 6 VA
Reaction Time	max. 15 ms
Signal Output Relay	
- Safety	2 A/250 VAC
- Service	2 A/250VAC per channel
Display	LED 3 mm
- Operation	green
- Safety Switch-off	yellow (2 for status relay)
- Error (Interruption)	red (2 per channel)
- Service	yellow (2 per channel)
Overvoltage	II (EN 61010-1)
Contamination Grade	2 (EN 61010-1)
Test Specifications	GS-BE-17 (Aug. 94) and ZH 1/494
Protection Class	0 (EN 60730-1 and EN 60335)

## Layout

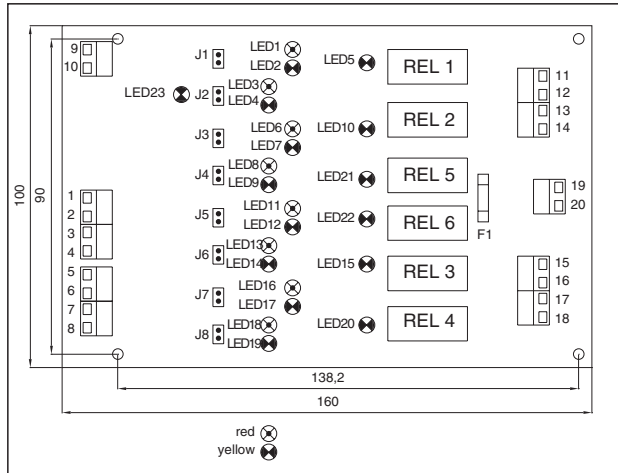

- |                               |  |
|-------------------------------|--|
| LED2, 4, 7, 9, 12, 14, 17, 19 | Function sensor (yellow)   |
| LED1, 3, 6, 8, 11, 13, 16, 18 | Error (red)  |
| LED5, 10, 15, 20              | Function display relay<br>Service (yellow)                             |
| LED21, 22                     | Function display relay<br>Safety (yellow)                              |
| LED23                         | Operation display (green)  |
| REL1, 2, 3, 4                 | Service  |
| REL5, 6                       | Safety   |
| F1                            | Fuse 2Amp slow,  |
| J1, 3, 5, 7                   | Relay contact protection<br>Test contact for<br>REL1, 2, 3, 4 and REL5 |
| J2, 4, 6, 8                   | Test contact for REL6  |

## Dimension Sheet

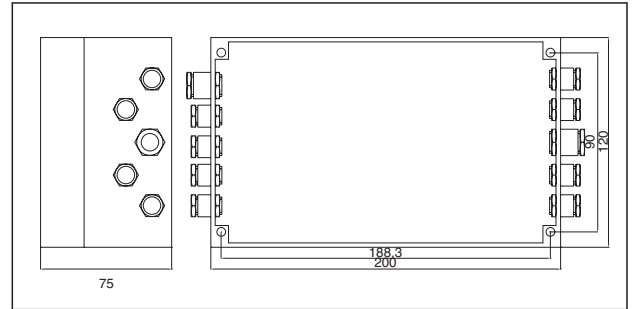

## Order Information

ESQ25-24VACDC



**INDUSTRIAL  
SAFETY SALES INC.**

P.O. Box 126 -- 4112 Sheridan Road  
Kenosha, WI 53141  
Fax: (262) 652-1388  
E-mail: [safetysensing@earthlink.net](mailto:safetysensing@earthlink.net)

**(262) 652-8660**