

Footswitches with single pedal

F1

Protection class IP 65



Designation	F1-U1Z	F1-U1Y	F1-SU1Z	F1-SU1 Mi RG
Part number	606.1100.005	606.1100.001	606.1300.011	616.1300.327
Circuit diagram				
	¹⁾ pressure point			
Slow make & break/snap action	●/-	●/-	-/●	-/●
Pressure point	-	-	-	-
Latching switch	-	●	-	-
Potentiometer	-	-	-	● 10 kΩ 2 W ²⁾
Pedal interlocking	-	-	-	-
Emergency stop function	-	-	-	-
Power contactor	-	-	-	-
Voltage	500 V AC	500 V AC	500 V AC	250 V AC DC
Permanent current	10 A	10 A	10 A	5 A
In-rush current complies with standards IEC 947-5-1 AC 15/DC 13	●	●	●	●
Switching frequency	50/min.	50/min.	50/min.	20/min.
Mechanical life – number of switching actions	10 x 10 ⁶	10 x 10 ⁶	10 x 10 ⁶	10 x 10 ⁶
Mechanical life – number of revolutions	-	-	-	50 x 10 ³ ³⁾
Operating temperature	-30 °C/+80 °C -22 °F/+176 °F	-30 °C/+80 °C -22 °F/+176 °F	-30 °C/+80 °C -22 °F/+176 °F	-30 °C/+80 °C -22 °F/+176 °F
Approvals	BG, CSA, UL	BG, CSA, UL	BG, CSA, UL	-
Cable entry	1 x M 20	1 x M 20	1 x M 20	1 x M 20
Weight	0.60 kg/1.3 lb	0.60 kg/1.3 lb	0.60 kg/1.3 lb	0.75 kg/1.65 lb
Delivery: ex-stock/built to order	●/-	●/-	●/-	●/-

All dimensions in mm (inch)

²⁾ other resistance figures on request

³⁾ number of revolutions available up to 5 x 10⁶

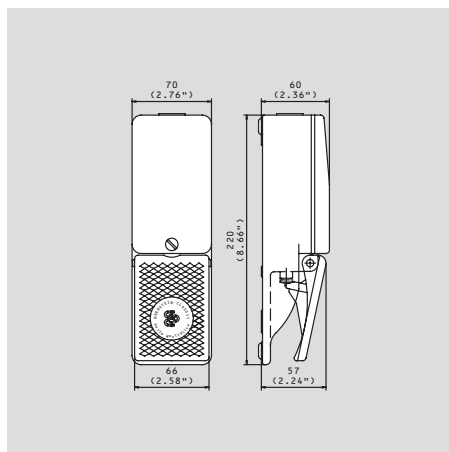



F1-U2Z
606.1200.003

F1-U2Z D
606.1200.007

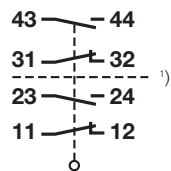
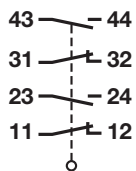

●/-	●/-
-	●
-	-
-	-
-	-
-	-

500 V AC	500 V AC
10 A	10 A
●	●

50/min.	50/min.
10 x 10 ⁶	10 x 10 ⁶
-	-
-30 °C/+80 °C	-30 °C/+80 °C
-22 °F/+176 °F	-22 °F/+176 °F

BG, CSA, UL BG, CSA, UL

3 x M 20 3 x M 20

0.60 kg/1.3 lb	0.70 kg/1.5 lb
●/-	●/-

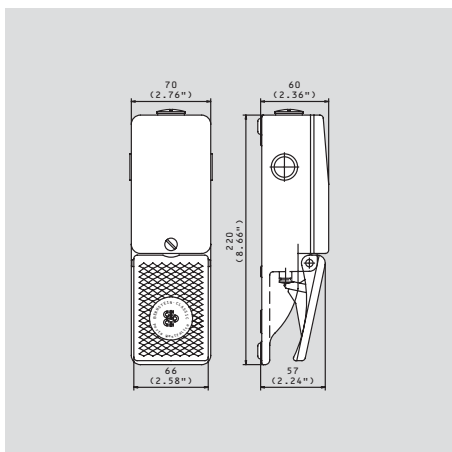

Footswitches with single pedal (guarded)

F1 UN

Protection class IP 65



Designation	F1-U1Z UN	F1-U1Y UN	F1-SU1Z UN
Part number	606.1600.006	606.1600.002	606.1800.012
Circuit diagram			
	1) pressure point 2) Emergency stop button – self latching		
Slow make & break/snap action	●/-	●/-	-/●
Pressure point	-	-	-
Latching switch	-	●	-
Potentiometer	-	-	-
Pedal interlocking	-	-	-
Emergency stop function	-	-	-
Power contactor	-	-	-
Voltage	max. 500 V AC	max. 500 V AC	max. 500 V AC
Permanent current	max. 10 A	max. 10 A	max. 10 A
In-rush current complies with standards IEC 947-5-1 AC 15/DC 13	●	●	●
Switching frequency	max. 50/min.	max. 50/min.	max. 50/min.
Mechanical life – number of switching actions	10 x 10 ⁶	10 x 10 ⁶	10 x 10 ⁶
Mechanical life – number of revolutions	-	-	-
Operating temperature	min./max. -30 °C/+80 °C -22 °F/+176 °F	min./max. -30 °C/+80 °C -22 °F/+176 °F	min./max. -30 °C/+80 °C -22 °F/+176 °F
Approvals	BG, CSA, UL	BG, CSA, UL	BG, CSA, UL
Cable entry	1 x M 20	1 x M 20	1 x M 20
Weight	1.50 kg/3.3 lb	1.50 kg/3.3 lb	1.50 kg/3.3 lb
Delivery: ex-stock/built to order	●/-	●/-	●/-

All dimensions in mm (inch)

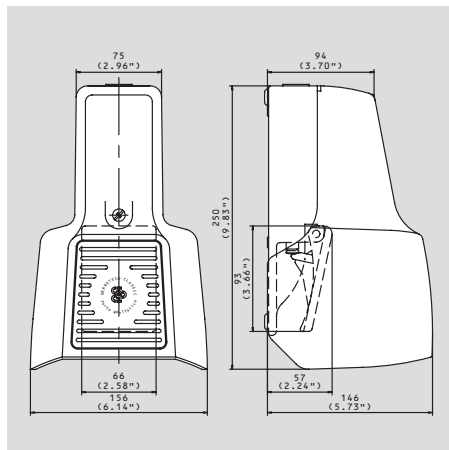



F1-U2Z UN
606.1700.004

F1-U2ZD UN
606.1700.008

F1-U1Z NA2 UN
606.1600.435

F1-U1Z AT UN
616.1600.400

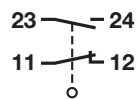
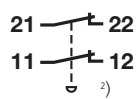
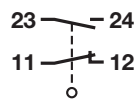
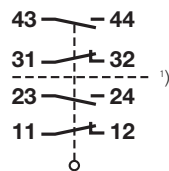
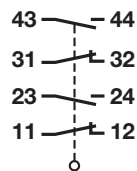

●/-	●/-	●/-	●
-	●	-	-
-	-	-	-
-	-	-	●
-	-	●	-
-	-	-	-

500 V AC
10 A

500 V AC
10 A

500 V AC
10 A

600 V AC
10 A

500 V AC
10 A

●	●	●	-	●
---	---	---	---	---

50/min.

50/min.

50/min.

50/min.

10 x 10⁶

10 x 10⁶

10 x 10⁶

10 x 10⁶

-30 °C/+80 °C
-22 °F/+176 °F

-30 °C/+80 °C
-22 °F/+176 °F

-30 °C/+80 °C
-22 °F/+176 °F

-30 °C/+80 °C
-22 °F/+176 °F

BG, CSA, UL

BG, CSA, UL

BG, CSA, UL

BG, CSA, UL

3 x M 20

3 x M 20

3 x M 20

1 x M 20

1.50 kg/3.3 lb

1.60 kg/3.5 lb

1.60 kg/3.5 lb

1.50 kg/3.3 lb

●/-	●/-	●/-	-/●
-----	-----	-----	-----

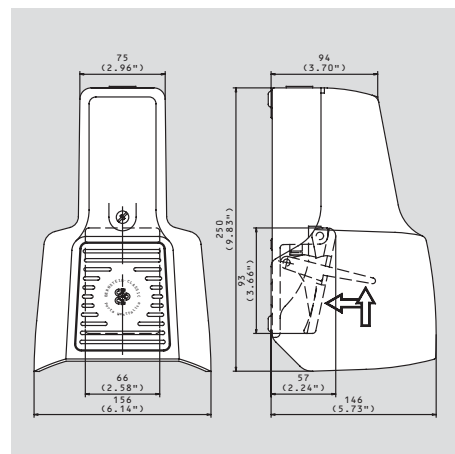
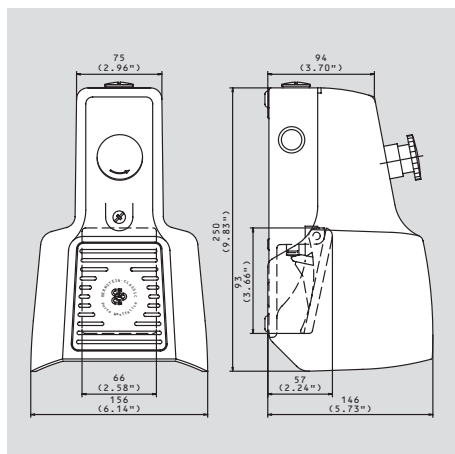
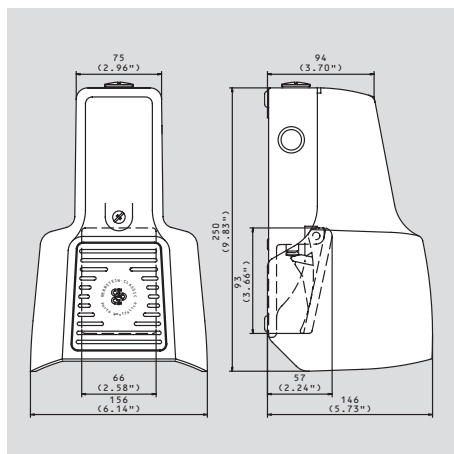

Safety footswitch

Safety latch with manual reset

Protection class IP 65



Designation		F1-SU1Z/UV1 DUN
Part number		616.1000.203
Circuit diagram		<p>1) pressure point</p> <p>2) latch</p>
Slow make & break/snap action		●●
Pressure point		●
Latching switch		●
Potentiometer		-
Pedal interlocking		-
Emergency stop function		-
Power contactor		●
		-
Voltage	max.	500 V AC
Permanent current	max.	10 A
In-rush current complies with standards		●
IEC 947-5-1 AC 15/DC 13		
Switching frequency	max.	50/min.
Mechanical life – number of switching actions		10 x 10 ⁶
Mechanical life – number of revolutions		
Operating temperature	min./max.	-30 °C/+80 °C -22 °F/+176 °F
Approvals		BG, UL, CSA
Cable entry		1 x M 20
Weight		1.50 kg/3.3 lb
Delivery: ex-stock/built to order		●/-

All dimensions in mm (inch)

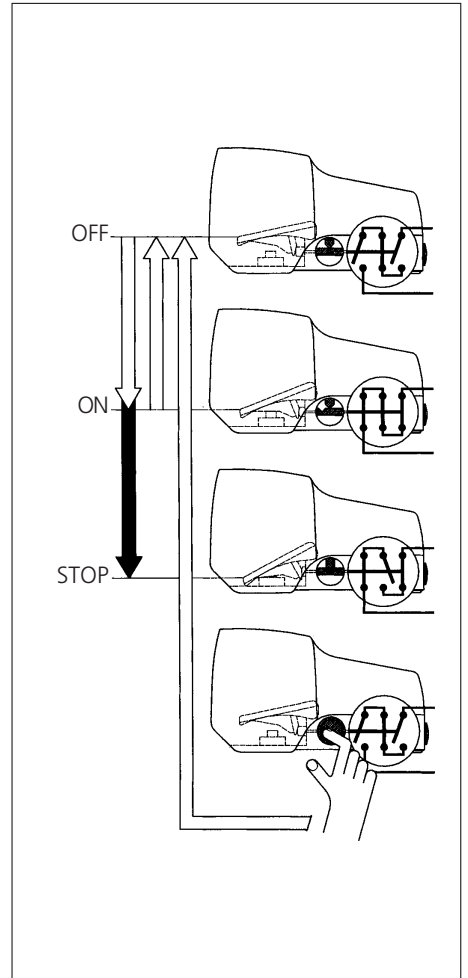
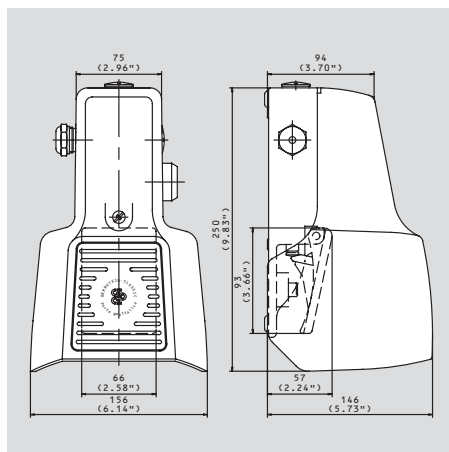

1. Depressing the pedal to the pressure point closes the contact and the operating process starts.
2. In an emergency situation the pressure point is overcome – the contact is opened and locked – the operating process is then interrupted. The latching mechanism holds the contact in the off position ensuring that an uncontrolled restart or new start of the machine cannot happen.
3. Interlocking: Only by releasing the locking device manually (reset button on the side of the housing), after the dangerous situation has been cleared, can the contacts be set to normal again. The operating process can then be repeated by operating the pedal to the pressure point.



**INDUSTRIAL
SAFETY SALES INC.**

P.O. Box 126 -- 4112 Sheridan Road
Kenosha, WI 53141
Fax: (262) 652-1388
E-mail: safetysensing@earthlink.net

(262) 652-8660