

Safety switching device

Emergency stop and safety gate monitors SNO 4062K / SNO 4062KM

Base device for single-channel or two-channel emergency stop, safety gate, safety mat/strip and light curtain applications

- Stop category 0 according to EN 60204-1
- Applications up to safety category 4 according to EN 954-1
- Safety category of the devices: 4 according to EN 954-1
- Reset button monitoring
- Single-channel and two-channel control
- Cross monitoring
- 2 enabling current paths, 1 signaling current path



Applications

- Monitoring of separating protective equipment
- Monitoring of rollup doors
- For processing signals from the output signal switching devices (OSSD) of a light curtain according to DIN EN 61496-1
- For connecting to a safety mat according to DIN EN 1760-1 (SNO 4062KM)

Function

SNO 4062K

The device is a two-channel switching device for emergency stop applications with self-monitoring on each ON-OFF cycle. It complies with EN 60204-1 and is equipped with positively driven relays.

Basic function:

With supply voltage applied to terminals A1/A2 and the safety inputs closed, operating of the reset button closes the enabling current paths (manual start). When the safety inputs are opened/de-energized the enabling current paths will open.

Operating modes / system functions

- **Single or two-channel control** With single-channel control both safety channels CH1 and CH2 are connected in parallel; with two-channel control they are switched separately.
- **Without cross monitoring** Both safety channels are switched to the positive potential (S12 and S31 to S11).
- **With cross monitoring** Safety channel CH1 is switched to the positive potential (S11 to S12), and safety channel CH2 to the negative potential (S21 to S22).
- **Manual start** When the safety inputs are closed, a button is used to open reset input S34 (triggering with falling edge) or to close reset input S35 (triggering with rising edge).
- **Automatic start** Reset input S35 is connected to S33. The device starts with the rising edge of the signal on safety input S12.
- **Start inhibit** After supply voltage has been applied and the safety inputs closed, the enabling paths will not close. Starting is only possible after the reset button has been operated. For start inhibit the reset inputs have to be controlled with the button, as with manual start mode.
- **Restart inhibit** No restart after the safety inputs have been opened and closed. Restarting is only possible after the reset button has been operated. For restart inhibit the reset inputs have to be activated with the button, as in manual start mode.
- **Semiconductor compatible** OSSD (output signal switching devices) signals from a light curtain or other safety sensors with semiconductor outputs can be processed. Test pulses $< t_{TP}$ do not influence the device functions. Test pulses $> t_{TP}$ can lock the device.

- **Synchrocheck** With two-channel control both safety channels are monitored against one another with the synchronous time t_s . Safety channel CH1 must close before CH2 and bridge S33/S35 must be connected. If CH2 closes before CH1, the synchronous time $t_s = \infty$ and synchrocheck is switched off.

SNO 4062KM

The function of this device corresponds to that of the SNO 4062K **without synchrocheck**. The device is suitable for connecting to light curtains for Si category 4 and connecting to short-circuit forming 4-wire safety mats, switching strips or switching edges (without monitoring resistance).

- **Safety mats** The device must be operated with two channels and cross monitoring. If there is resistance $< 50 \Omega$ / channel and a short circuit between the channels (S11/S12 and S21/S22) the enabling paths open and the SUPPLY LED flashes.
- **Light curtain for Si category 4** The device will be operated with two channels and without cross monitoring, if the light curtain connected to the OSSD detects a shunt fault on its own.
- **Input debouncing** Input debouncing prevents fast consecutive switching of the enabling current paths when the safety inputs are opened for less than t_{ASP} . Safety inputs opened for longer than t_{ASP} lead to opening of the enabling current paths after t_{BP} . Restarting is blocked for time t_{SP} . For applications with tactile operating modes (rapid ON-OFF cycles, for example with manual supply) we recommend the use of SNO 4062KM.

Circuit diagram

SNO 4062K / K-A / KM / KM-A

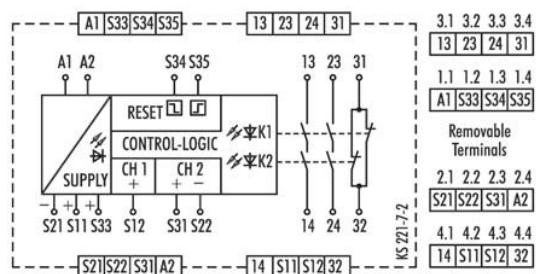

Safety switching device

Emergency stop and safety gate monitors SNO 4062K / SNO 4062KM



Function diagram	Dimension diagram
<p>SNO 4062K Manual start (installation 3)</p> <p style="text-align: center;">FD 221-4-1 W</p> <p> t_M = minimum ON time, t_{A1} = response time t_{TP} = test pulse time, t_R = release time t_W = recovery time </p>	<p>SNO 4062K / SNO 4062KM</p>
<p>SNO 4062KM Automatic start (installations 2 and 4)</p> <p style="text-align: center;">FD 221-4-2 W</p> <p> t_{SP} = disable time, t_{AZ} = response time t_{TP} = Test pulse time, t_{ASP} = response time of the disable t_R = release time, t_W = recovery time </p>	<p>SNO 4062K-A / SNO 4062KM-A</p>
<p>Notes Proper use</p> <p>The devices are safety switching devices. They must only be used as components of safety equipment on machines for the purpose of protecting people, material and machines.</p> <ul style="list-style-type: none"> • The safety category according to EN 954-1 depends on the external circuitry, the choice of control devices and their placement on the machine. • The indicated times must be observed when the device is operated, otherwise the device could lock. Locking can be released by properly opening the safety inputs. • SNE expansion devices or external contactors with positively driven contacts can be used to multiply the enabling current paths. • The device and the contacts must be protected with max. 6 A utilization category gG or through circuit breakers with trigger characteristic B or C. • The devices are equipped with overload protection (for short circuit). After the cause of the malfunction has been removed, the device is operational again after approx. 3 s. • Control output S11 is exclusively for connecting control devices as defined in the operating instructions and not for connecting external field devices such as lamps, relays or contactors. • The devices must be installed in a control cabinet with a protection degree of at least IP 54. <p>Please also note the information provided by your trade association.</p>	

Safety switching device

Emergency stop and safety gate monitors SNO 4062K / SNO 4062KM

Installation

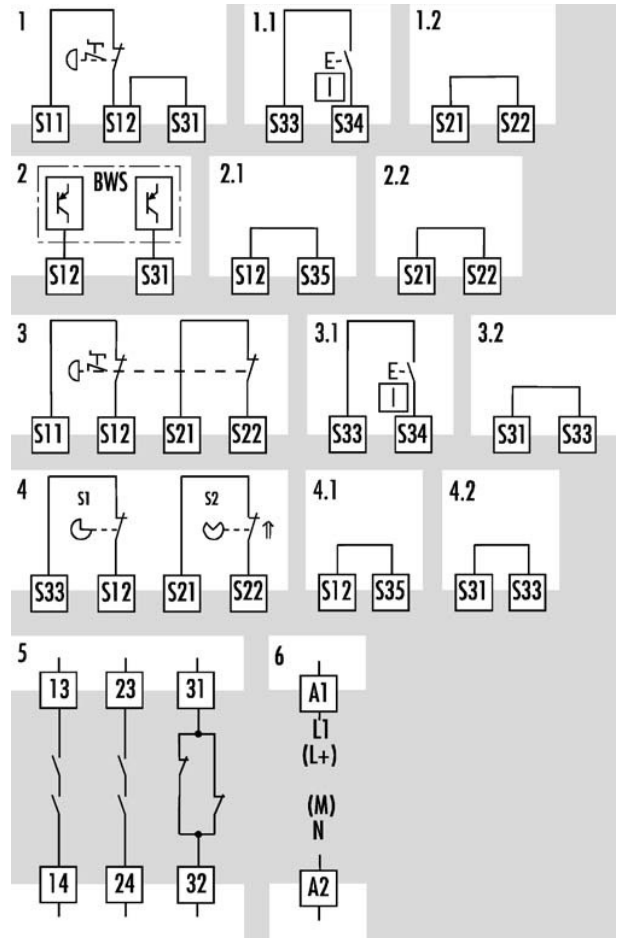

	Please consult the circuit diagram during installation.
1	Emergency stop single channel, manual start
1.1	RESET (with reset button monitoring S34)
1.2	Bridge
2	OSSD control two-channel, without cross monitoring,
2.1	Bridge, RESET with automatic start
2.2	Bridge, CH2-
3	Emergency stop two-channel, with cross monitoring and manual start
3.1	RESET (with reset button monitoring S34)
3.2	Bridge, CH2+
4	Safety gate applications two-channel, with cross monitoring, synchrocheck (S1 must be operated before S2)
4.1	RESET with automatic start
4.2	Bridge, CH2+
5	2 enabling current paths 1 signaling contact
6	Supply voltage

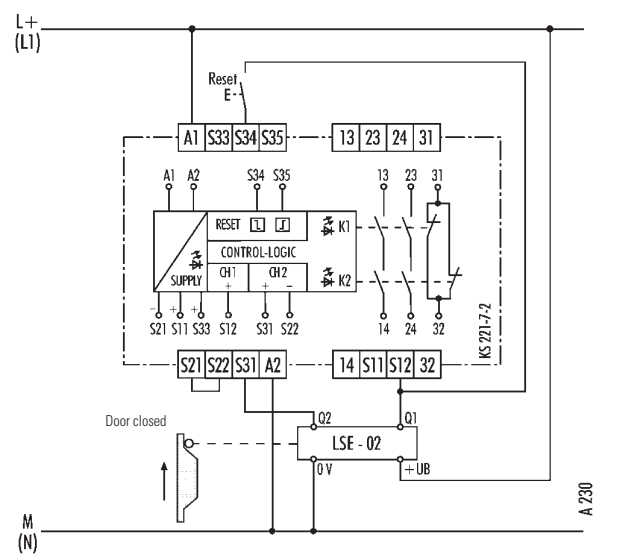

Application example
SNO 4062K – Two-channel sliding safety gate monitoring with manual start
 Position switch LSE-02 from the company Moeller is used.

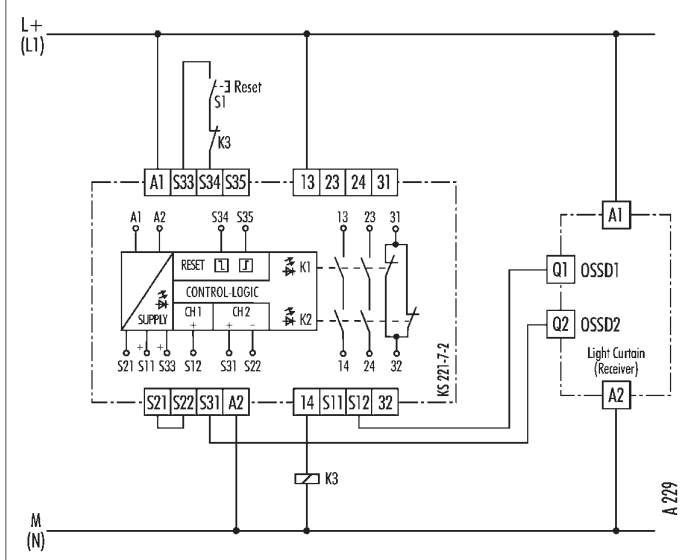

Application example
SNO 4062KM
 Two-channel light curtain monitoring with manual start.

Safety switching device

Emergency stop and safety gate monitors SNO 4062K / SNO 4062KM

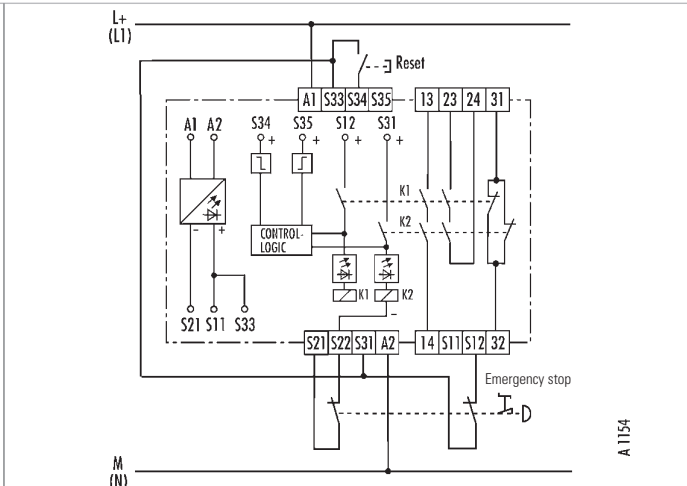
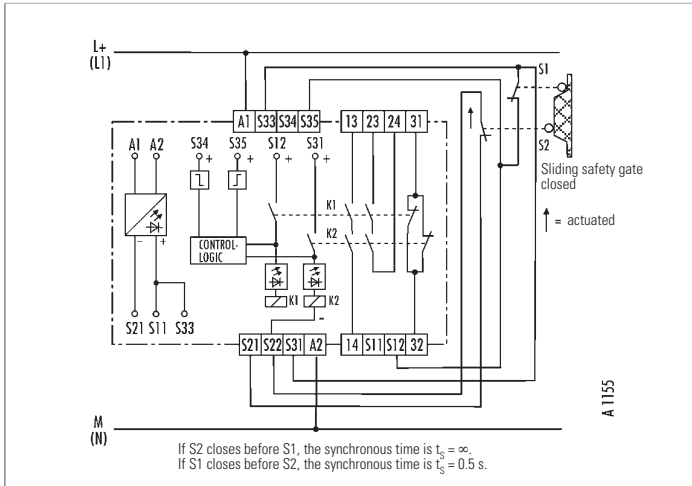

Application example
Two-channel sliding safety gate application (with cross monitoring) with manual start
 Channel 1 (S12) and channel 2 (S22) monitor the position of the sliding safety gate. The automatic start through terminal S35 activates the SNO 4062K/SNO 4062KM. If the sliding safety gate opens, K1 and K2 switch back into the OFF position (enabling current paths 13/14, 23/24 are opened). If the safety gate is closed again, the automatic start at terminal S35 activates the device again.

Application example
Two-channel emergency stop application (with cross monitoring) with manual start and reset button monitoring
 The two-channel emergency stop application switches off the device even if one of the two contacts of emergency stop button does not open. If an error occurs (for example when the emergency stop contact connected to terminal S12 does not open), the second (redundant) contact S22 will activate safety circuit. The enabling current paths 13/14 and 23/24 open. In case of a short circuit in the lines leading to the emergency stop button, the voltage applied to S11, S21 is short-circuited (cross monitoring). The relays K1, K2 switch back into the OFF position and the electronic fuse is triggered. If a line short circuit occurs in the reset button after the relay has been activated, this will be recognized by the cyclical self test when reactivating the device. This will inhibit the enabling current paths from closing again.

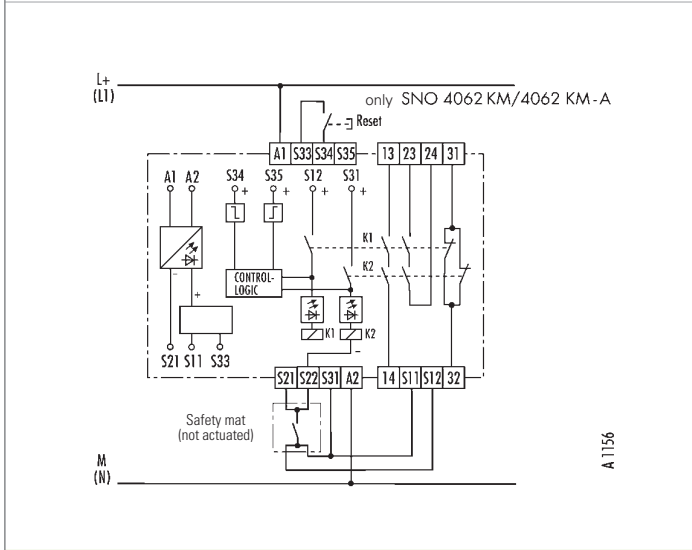

Application example
Two-channel safety mat application (with cross monitoring) with manual start and reset button monitoring
 The safety mat connected to terminals S21, S22 and S11, S12 is monitored by means of cross monitoring. If the safety mat is not actuated (no one is stepping on it), the SNO 4062KM can be activated with the reset button. The enabling current paths 13/14, 23/24 close and the signaling current path 31/32 opens. If a person steps onto the safety mat, a short circuit is generated causing the immediate release of the K1 and K2 relays. The enabling current paths open and the signaling current path closes.

Safety switching device

Emergency stop and safety gate monitors SNO 4062K / SNO 4062KM

Technical data		SNO 4062K	SNO 4062KM	
Function according to EN 60204-1		Emergency stop relay		
Function display		3 LEDs green		
Function diagram		FD 0221-4-1 W, FD 0221-4-2 W		
Power supply circuit				
Rated voltage U_N		AC/DC 24 V		
Rated consumption DC		2.0 W	2.1 W	
Rated consumption AC		2.4 W/4.4 VA	2.5 W/4.6 VA	
Residual ripple		2.4 V _{eff}		
Rated frequency		50 – 60 Hz		
Operating voltage range		0.85 – 1.1 x U_N		
Fuse for control circuit supply		Short-circuit resistant PTC thermistor	Short-circuit resistant electronic fuse	
Control circuit				
Rated output voltage (S11, S33 to S21)		DC 22 V		
Output current / peak current		100 mA/2000 mA	100 mA/300 mA	
Input voltage range		high low	DC 17.4 V – DC 26.4 V DC -3.0 V – DC +5.0 V	
Rated current / peak current (S12, S31/S22)		40 mA/100 mA		
Rated current / peak current (S34, S35)		5 mA/50 mA		
Permissible test pulse time t_{tp} / test frequency		≙ 1000 µs / ≙ 10 s ⁻¹		
Response time t_{d1} (S34)		20 ms – 40 ms		
Response time t_{d2} (S35)		200 ms – 500 ms	20 ms – 60 ms	
Minimum ON time t_{on} (S34, S35)		> 50 ms		
Locking time t_{Lp}		-	70 ms – 130 ms	
Response time of the lock t_{Ld}		-	> 7 ms	
Recovery time t_{re}		≙ 40 ms	≙ 150 ms	
Release time t_{re} (K1, K2)		< 25 ms		
Synchronous monitoring time t_s		ca. 200 ms	-	
Max. resistance for short-circuit forming safety mats including connection cables		-	≙ 50 Ω	
Line resistance		< 70 Ω		
Output circuit				
Enabling paths				
Contact assignment		2 NO contacts, positively driven		
Rated operating voltage U_N		AC 240 V/DC 300 V		
Max. continuous current I_N per contact		6 A		
Max. total current of all current paths		12 A		
Application category according to EN 60947-5-1		360 h ¹ 3600 h ¹	AC-15: U_N 230 V AC, I_N 4 A / DC-13: U_N 24 V DC, I_N 4 A AC-15: U_N 230 V AC, I_N 3 A / DC-13: U_N 24 V DC, I_N 2.5 A 10 x 10 ⁵ switching cycles	
Mechanical life				
Signaling paths				
Contact assignment		1 NC contact, parallel, positively driven		
Rated operating voltage U_N		AC 240 V/DC 300 V		
Max. continuous current I_N per contact		6 A		
Application category according to EN 60947-5-1		360 h ¹ 3600 h ¹	AC-15: U_N 230 V AC, I_N 4 A / DC-13: U_N 24 V DC, I_N 4 A AC-15: U_N 230 V AC, I_N 3 A / DC-13: U_N 24 V DC, I_N 2.5 A 10 x 10 ⁵ switching cycles	
Short-circuit protection, max. fuse insert		6 A class gG or circuit breaker with trigger characteristic B or C		
Mechanical life				
General data				
Creepage distances and clearances between the circuits		according to EN 60664-1		
Rated impulse voltage		4 kV		
Overvoltage category		III		
Degree of pollution of the device: inside / outside		2/3		
Rated voltage		AC 300 V		
Test voltage U_{tr} 50 Hz		2 kV		
Protection degree according to DIN EN 60529 (housing / terminals)		IP 40/IP 20		
Ambient temperature / storage temperature		-25 – +55 °C / -25 – +75 °C		
Dimension diagram		K 4-1 (screw terminals) / K 4-2 (pluggable terminals)		
Rated cross sections fine-stranded/solid or fine-stranded with ferrules		2 x 0.14 – 0.75 mm ² / 1 x 0.14 – 2.5 mm ² 1 x 0.25 – 2.5 mm ² / 2 x 0.25 – 0.5 mm ²		
Permissible tightening torque		0.5 – 0.6 Nm		
Weight		0.21 kg		
Approvals				
Overview of devices / Part numbers				
Type	Rated voltage	Terminals	Part no.	Std. Pack
SNO 4062K	AC/DC 24 V 50 – 60 Hz	Terminal block, rising cage termination	R1.188.0650.2	1
SNO 4062K-A	AC/DC 24 V 50 – 60 Hz	Pluggable connector, rising cage termination	R1.188.0700.2	1
SNO 4062KM	AC/DC 24 V 50 – 60 Hz	Terminal block, rising cage termination	R1.188.0710.2	1
SNO 4062KMA	AC/DC 24 V 50 – 60 Hz	Pluggable connector, rising cage termination	R1.188.0720.2	1